

# Knotting Matters

The Magazine of the International Guild of Knot Tyers



Issue 88  
September 2005

# Guild Supplies

## Price List 2005

<b>Item</b>	<b>Price</b>
<b>Knot Charts</b>	
Full Set of 100 charts	£10.00
Individual charts	£0.20
<b>Rubber Stamp</b>	
IGKT Member, with logo (excludes stamp pad)	£4.00
<b>Guild Tie</b>	
Long, dark blue with Guild Logo in gold	£8.95
<b>Badges - all with Guild Logo</b>	
Blazer Badge	£1.00
Enamel Brooch	£2.00
Windscreen Sticker	£1.00
<b>Certificate of Membership</b>	£2.50
Parchment membership scroll Signed by the President and Hon Sec For mounting and hanging	

Cheques payable to IGKT, or simply send your credit card details  
**PS** Don't forget to allow for postage

**Supplies Secretary: - Bruce Turley**  
**19 Windmill Avenue, Rubery, Birmingham B45 9SP**  
**email [bruce.turley@blueyonder.co.uk](mailto:bruce.turley@blueyonder.co.uk)**  
**Telephone: 0121 453 4124**



# Knotting Matters

**Magazine of the  
International Guild of  
Knot Tyers**

**Issue No. 88**

**President: Ken Yalden  
Secretary: Nigel Harding  
Editor: Colin Grundy  
Website: [www.igkt.net](http://www.igkt.net)**

**Submission dates for copy  
KM 89 17 OCT 2005  
KM 90 17 JAN 2006**

The IGKT is a UK Registered  
Charity No. 802153

Except as otherwise indicated, copyright  
in Knotting Matters is reserved to the  
International Guild of Knot Tyers IGKT  
2005. Copyright of members articles  
published in Knotting Matters is reserved  
to the authors and permission to reprint  
should be sought from the author and  
editor. All sources of quotations printed  
in Knotting Matters are acknowledged.  
ISSN 0959-2881



*Front Cover - Young fender maker in  
training at Peterborough Boat Festival -  
photo Tim Fish*

## IN THIS ISSUE

<b>Compact-Knotboard</b>	<b>2</b>
<b>Book Review</b>	<b>3</b>
<b>The Reeve and Sennit Knots</b>	<b>4</b>
<b>The Johnson Hitch - Correction</b>	<b>7</b>
<b>Health Check-Up</b>	<b>8</b>
<b>A Ropy Chess Set Pt III</b>	<b>9</b>
<b>Cordage and Me</b>	<b>14</b>
<b>Knotmaster</b>	<b>14</b>
<b>The Modified Tarbuck Knot</b>	<b>16</b>
<b>Bowline Failure</b>	<b>19</b>
<b>Devil's Rope</b>	<b>20</b>
<b>Knot Gallery</b>	<b>22</b>
<b>The Rosary Knot</b>	<b>28</b>
<b>Branch Lines</b>	<b>38</b>
<b>Postbag</b>	<b>44</b>

# Col's Comment

A member recently commented that he had joined the Guild to learn more about decorative rope work. He felt that *Knotting Matters* had moved more in the direction of the more technical side of knotting. That may be so. There are two sides to this viewpoint.

The Guild is made up of members with many diverse interests in knot tying and rope work, and it is this diversity that is one of its strengths. Speaking from a personal point of view, I enjoy decorative rope work, which I find both relaxing and challenging. I can appreciate the time and skill that has gone into work many of our members display, and only hope to one day reach that standard. I am also a practical rope worker, and do more of this type of work than decorative, this I can also find challenging. Frank Brown (Tasmania) commented recently in *Knotting Matters*, that it would be good to know of other member's interests or specialities, then dialogue could be held between those of like minds.

The second part to the comment about the content of *KM* is that it reflects what members submit. And yes, he has a point. Perhaps the magazine has gone more to the technical side, but that is the content of the editorial drawer. To the best of my knowledge, *KM* has never commissioned articles but has to rely on what you, the membership submit. So, the answer to that one lies in your own hands.

## Compact-Knotboard

by Theo Slijkerman

With a CD-jewel case and some simple knots you can make a little original and nice knotboard. It's no compact-disc (CD), but a compact-knotboard (CK).

Material:

- CD jewel case, with black frame
- white cotton, 2 m long, 2mm width
- gum (also to treat the ends)
- printed cover

I have made a design, you can use directly. Download the cover for the back of the jewel case from <http://home.hetnet/~splits/knots60/0.htm>. My website is in Dutch, but I use many images and for these cover I have made also an English version.

For IGKT members the most knots are quite simple, they need no explain.

The description of the carrick mat is printed on the cover and the braid knot also stands on my website.

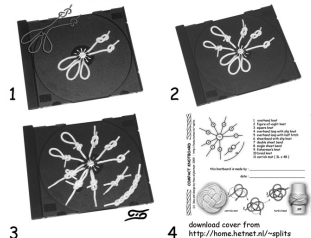
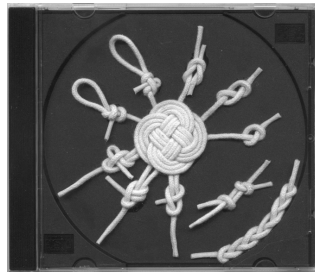



# Book Review

**A PIECE OF STRING is a Wonderful Thing** by Judy Hindley illustrated by Margaret Chamberlain published in 1993 (2nd edition 2001) by Walker Books Ltd  
ISBN 0-7445-8208-3  
price: UK £4.99

I am grateful to Don Woods<sup>IGKT</sup> (Essex) for bringing this book to my notice. It is one of the publisher's acclaimed *Read and Wonder* series designed to help teachers stimulate children to

discover more about particular topics. This edition outlines humankind's evolution and development from cave to city dweller through the use of string and other cordage.

It is a slim, soft-cover book, 250mm tall x 230mm wide (in inches, approximately 10 x 9), consisting of just 16 pages filled with comical drawings and a text of subtle rhymes and rhythms. Few words contain more than two syllables, making it easy for young people to read aloud (or to absorb if it is

'And they spun out the fibres of vegetable fluff  
and they felted the hairs of a goat,  
and they knitted and twisted and plaited and twined ...  
and invented the three-ply rope!'

So the story of string is told - in words and pictures - with examples that include stitched skin and fur garments, halters and harnesses, pontoon bridges, plumb lines and land surveying, early flying machines, trapezes and tennis racquets and yo-yos.

I was disappointed to find that actual knots and lashings receive scarcely a mention. Also - perhaps because of the book's original publication date - the drawings are almost all gender specific

(male hunters, crane operator, car driver and helicopter pilot; female spinners and weavers and child minders), while the ethnic mixture of characters fails to reflect what is now the norm in most places I frequent; and these are both, in my experience, crucial considerations when choosing books for today's urban child. Still, this is an inoffensive yet stimulating bit of fun, worth looking for when buying books for (say) the under-10's.

**G.B.**

# The Reeveer and Sennit Knots

reported by Geoffrey Budworth

*'These knots are new in the sense that no earlier record of them has been traced. But it might be rash to claim that they have never been used before.'*

(C.I.E. Wright and J.E. Magowan, '*Knots for Climbers*', Alpine Journal, Volume 40, No 236, May 1928)

I was made aware of Wright and Magowan many years ago by both Lester Copesteak and Charles Warner, but I am indebted to Dick Clements who recently sent me photocopies of their two 1928 articles in which the Reeveer and Sennit knots appear.

The Reeveer knot is obviously identical with the Vice Versa devised by the late Harry Asher and featured in *The Alternative Knot Book* (London, 1989). Guild members must now amend their databases, mental, manuscript and electro-magnetic, to register the earlier name.

The Reeveer and Sennit knots were, it seems, invented or discovered by Wright and Magowan to join hawser-laid climbing ropes of flax or manila. They are effective, however, in synthetic sheath-&-core (*kernmantel*) or braid-on-braid constructions and will even cope with bungee cord (shock elastics).

Shrewd observers of the contemporary knotting scene will realise that this is the third time in 20 years that I have had to shift my stance on certain

'new' knots. Dr. Edward Hunter's bend (1978) turned out to be Phil D. Smith's rigger's bend (early 1940s); and Desmond Mandeville's Poor Man's Pride (1982) was actually the Zeppelin knot or bend (1930s) of Commander Rosendahl. Critics may query this trial-&-error approach of mine, but it is the only way I know that leads more often than not to further revelations.

In my defence I quote the New Zealand born writer Kathleen Mansfield (1888-1923) who advised; 'Don't get it right; get it written.' Also Captain Paul Harrison, author of *The Harrison Book of Knots* (London, 1964) who told me; 'There came a time when I had to put my fingers in my ears and tell myself I didn't know any more.'

Neither of these two was condoning slap-dash research, or - worse - the journalists' axiom 'Don't let the facts spoil a good story' (also referred to as TGTV: too good to verify). Rather their comments were cautionary ones for those would-be writers who may never make it into print because of a compulsive and never-ending hunt for more proof and provenance.

Anyway, knot tyers who - like Edward, Desmond and Harry - genuinely re-discover and promote the use of knots which ultimately prove to have existed in an earlier era, but which had been neglected, mislaid and then forgotten, deserve almost as much credit (it seems to me) as if their creations were truly original.



# Reever knot

1

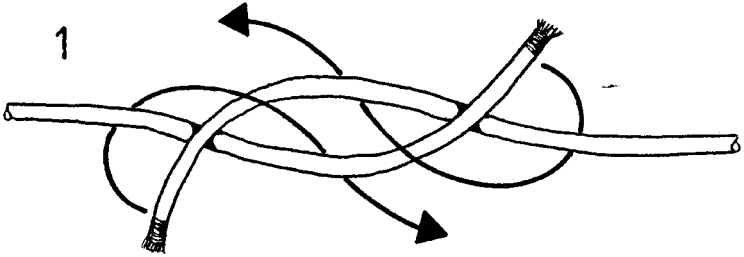

2

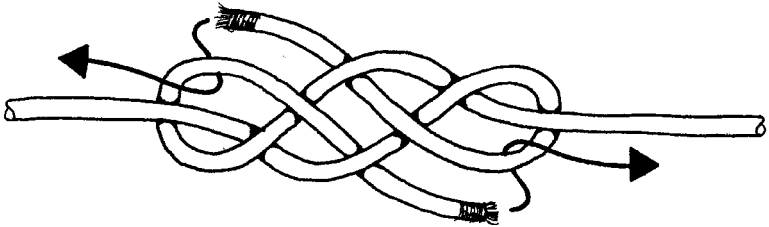

3

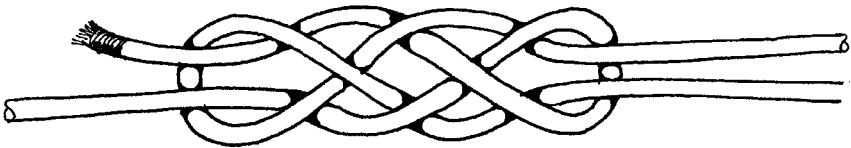

4

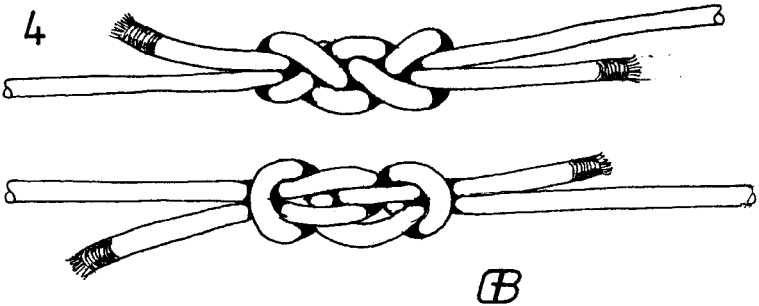

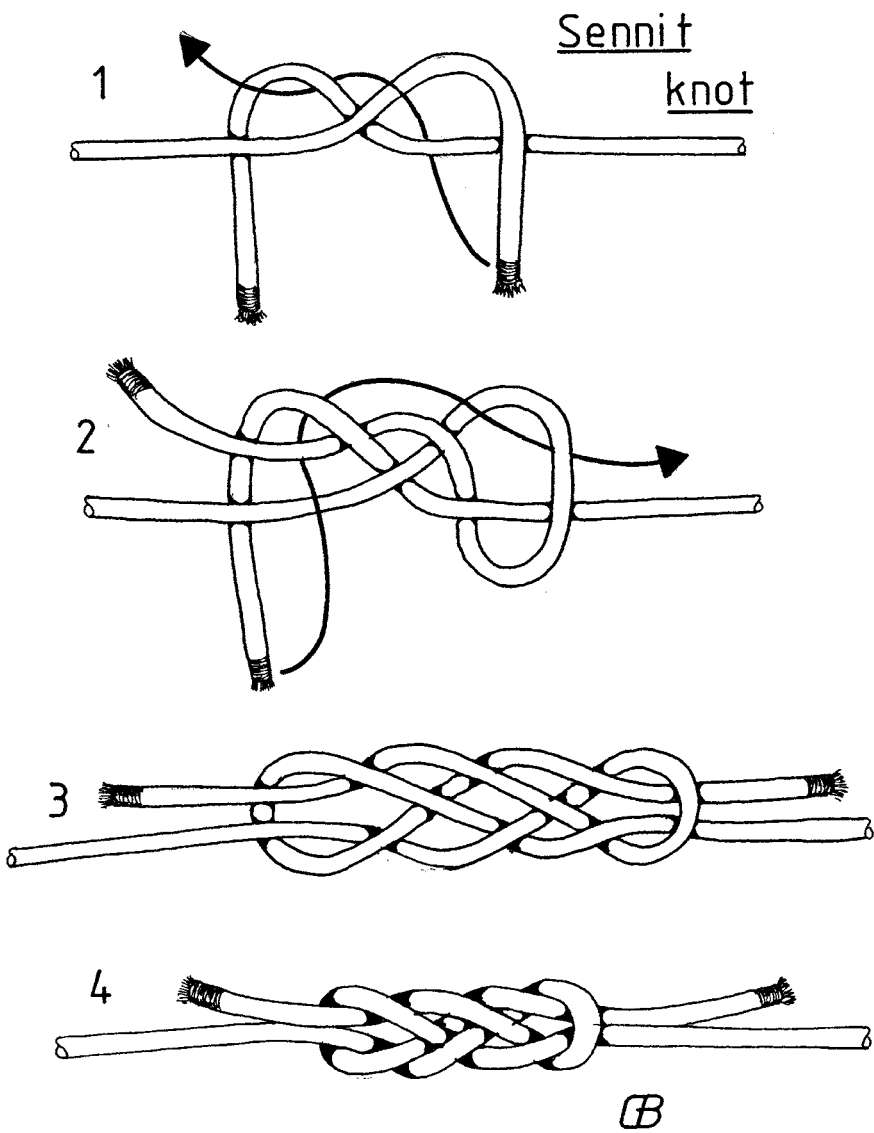



# The Johnson Hitch - a Correction

It has been brought to my attention, that the illustrations of the 'Johnson' hitch, developed by Captain Roger L Johnson, of the Ramona Fire Department, California (*Knotting Matters* 82) was incorrect. The illustration shows a previous version that would fall apart in use. The correct and current version is printed below. *Editor*

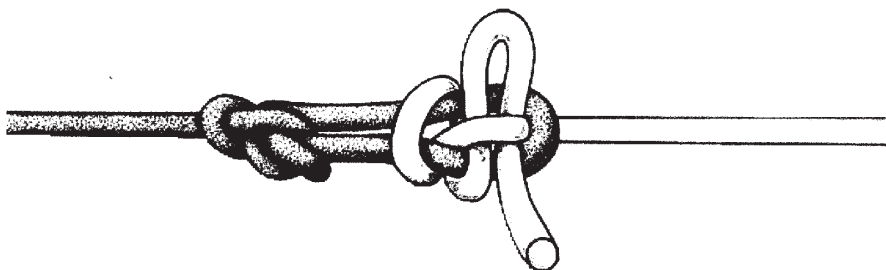
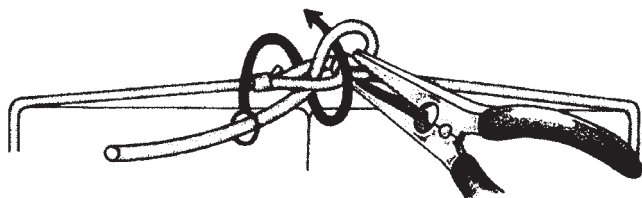
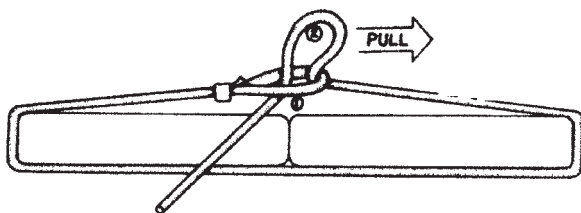

# 10-Point Knottological Health Check-Up

by 'Knut Canute'

**Do you:**

- possess a fid?
- carry a length of cord in your pocket?
- prefer lace-up shoes?
- own a knot book?
- wonder about bondage?
- know a trick knot?
- whip or seize frayed ropes' ends?
- sniff tarred spunyarn?
- wash dirty cordage?
- save string?

SCORE one point for every answer 'YES'.

**RESULT:**

- 8-10 You have the full-blown addiction commonly known as knottology. There is no known cure. The good news, however, is that it is neither immoral nor illegal (nor is it fattening), so pursue this pleasurable indulgence before government decides to licence and tax it.
- 6-7 You reveal marked signs and symptoms of the knottological condition. If these persist, despite the concerns of worried family and friends, then see 8-10 (above).
- 3-5 There is still time to undertake some remedial distraction therapy, such as: line-dancing; breeding pet iguanas; and/ or collecting antique thimbles.
- 2 or less You are probably immune and therefore unlikely - despite exposure to knottologists - ever to become infected with their compulsion to tie knots.



# A Ropy Chess Set - Part 3

by Frank Brown

## **Knights Horse**

The construction of the Knight has been described in Part 1, so this section deals with his steed. Single strands of the three strand line are used to construct the horse as they are for the Knight.

Prepare eight strands about 300mm, (1 ft), and seize in the middle. Crown for four rows, either continuously left or right, or alternating left and right. Remove the seizing and crown for

another four rows to create the torso. See Fig. 3-1.

Take two non-adjacent lines and relocate them through the body to emerge immediately behind two adjacent lines at the "top" of the torso to provide the base of the neck and head. Crown in one direction for five rows to make the neck as seen in Fig.3-2. Locate the two lines at the back of the neck through the sinnet to provide the basis for the rest of the head as in Fig 3-3.

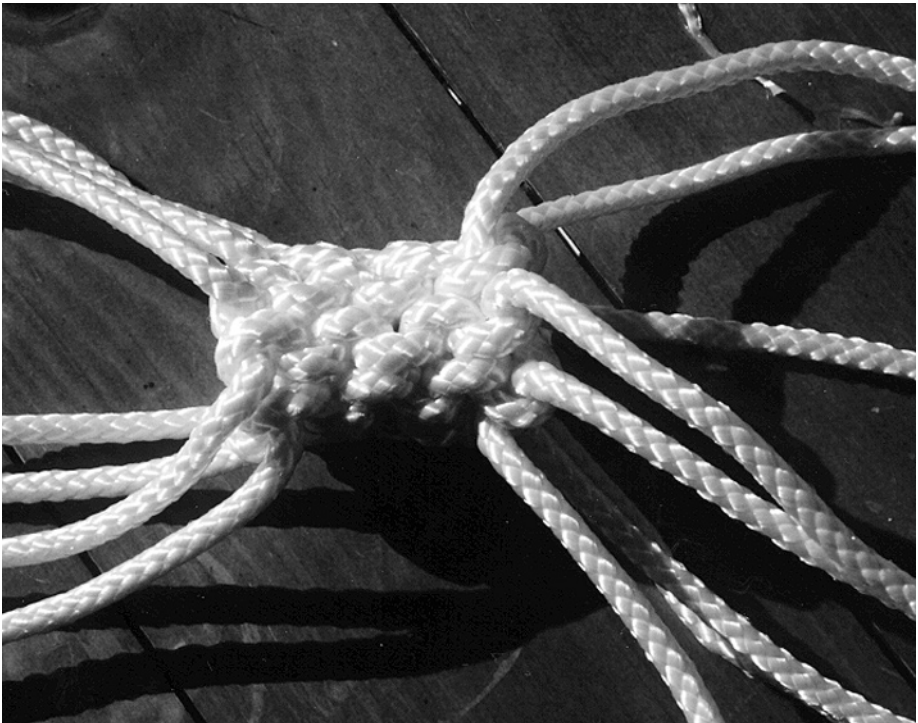

Fig 3-1



*Fig 3-2*

Crown for four rows, cut surplus and seal as per Fig 3-4.

At the front of the torso, relocate the upper two lines through the torso



*Fig 3-3*

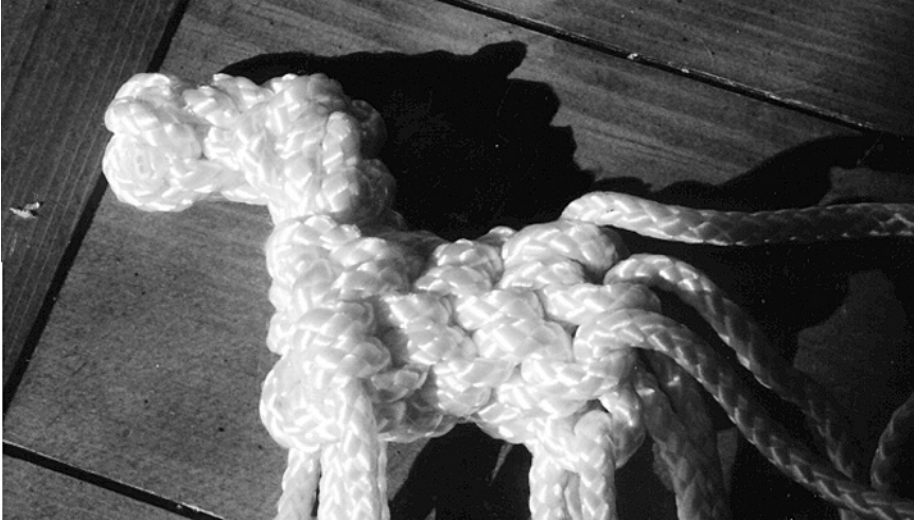

*Fig 3-4*

to positions close to the lower lines as shown in Fig 3-5. At the hind end, four

of the lines located on the sides of the torso are relocated to the rear, belly area.



*Fig 3-5*

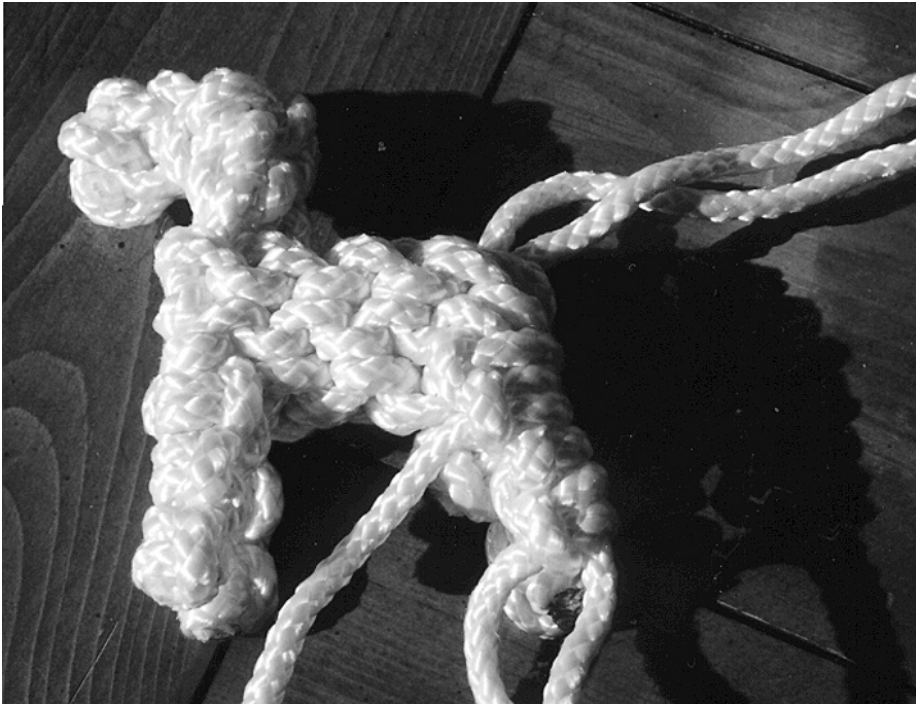

*Fig 3-6*



*Fig 3-7*





Fig 3-8

One is relocated to emerge next to the topmost line. See Fig 3-5.

Commence to form the fore legs by alternate halfhitching (Cackling) for about six rows. For the rear legs, half hitch with one line for two or three rows around two lines, then another three rows around a single line. See Fig 3-6. Cut surplus and seal.

Using the surplus lengths, make the mane by threading a number through

the neck as shown in Fig 3-7. Cut to an appropriate length and tease out these and the two lines at the rear. The resulting creation should resemble Fig 3-8.

Four of these pieces need to be assembled.

The two pieces are united and fastened together by sewing.

*To be continued.*

---

## THE COST OF LOVING

*by our South of England stringer*

*An IGKT member was recently in a big city sex shop - which he had entered (he assures me) merely to ascertain the latest cricket scores - when he espied, amid the multifarious items of merchandise on display, some hanks of brightly coloured, 12 mm diameter, braided polypropylene cordage labelled 'Soft bondage rope'.*

*Could this be, he wondered, a previously unsuspected source of useful knotting material? Well, no - not at £5 a metre - because each 10 metre length in its simple plastic packaging was priced at a breathtaking £49.99p. The cost of loving just goes up and up.*



# Cordage and Me

by 'Jennifer Wren'

When I was young and colourful,  
Hawsers were drab and unlovable.

They came in shades of brown or  
blonde

From the Philippines and Trebizond,

There was coir, hemp and sisal  
(lots),

Plus soft white cotton for big posh  
yachts.

Manilla and flax also played  
Their roles in this cordage caval-  
cade.

But most were coarse and kind of  
fuzzy,

As hard-laid as a sailor's hussy;  
And how they hurt my girlish hands  
With their fibrous yarns and prickly  
strands

But now I'm wrinkled, grey and old,  
Cordage comes coloured: silver and  
gold,

rainbow spectra, subdued hues,  
fluorescent pink and outrageous  
blues

They're trendy, bendy, slim and  
slick,

Braided as soft as a day-old chick.

Synthetic stuff I love to tie  
And will do until the day I die.

# Knotmaster Series No. 26

*'Knotting ventured,  
knotting gained.'*

## Double constrictor knot

The basic constrictor knot can be reinforced by simply tying a second one alongside the first knot; but a double constrictor is a neater solution.

**Method one** (tied with an end): On a ring or rail with no accessible ends, wrap, tuck and tighten as shown (fig's 1, 2).

**Method two** (tied in the bight): When the end of the object to be seized is available, it is quicker, slicker and preferable to tie the knot this way. Make a clove hitch (fig. 3) and bring the working end across the front of the knot, as shown (fig. 4). Pull out a bight as indicated, twist it to form a loop, and place it over the end of the foundation (fig. 5), then tighten the resulting knot (fig. 6). Tying in the bight this way was first described by Guild member Brion Toss, of Port Townsend, in Washington State, USA, in his book *Knots* (1990).

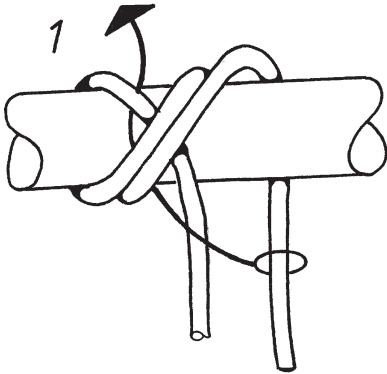

Method Two

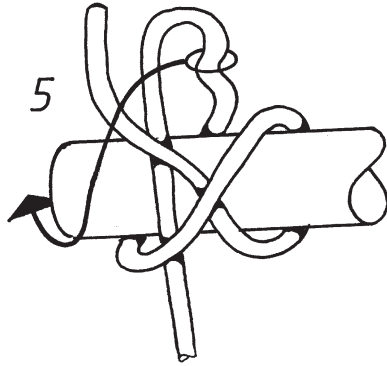
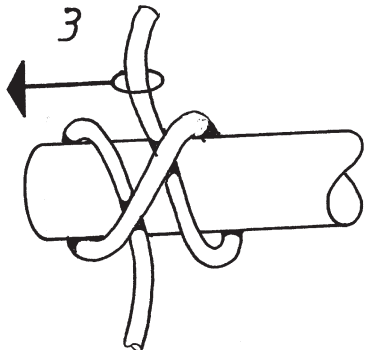

Method One

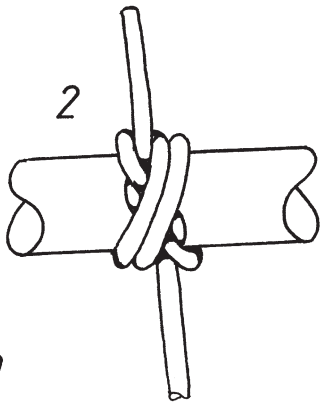

Double  
constrictor

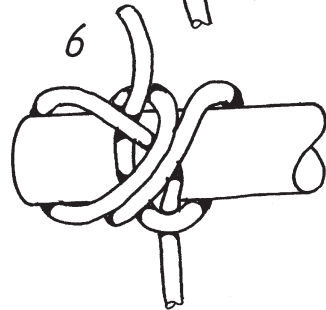
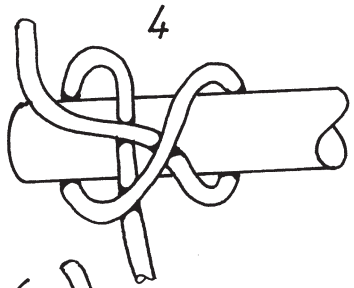

# The Modified Tarbuck Knot

by Rob Chisnall

I saw the Tarbuck knot profiled in *Knotted Matters* 83, so I thought it was about time I formally presented the following variation for the record.

I first encountered the Tarbuck knot in *The Arrow Book of Climbing* by Showell Styles (1966)- a knot described as a tie-in technique, a loop that can be clipped into a climber's "waist length," climbing swami, or waist harness (which are now antiquated harnessing systems). "This knot allows the loop of the rope to be clipped into the krab [carabiner], and will tighten and slide grudgingly under tension, thus giving an extra margin of safety in the event of a bad fall on the rope [presumably reducing the impact force and absorbing kinetic energy]." (page 32). But that book also contained a photograph of a climber with the caption: "Note, by way of warning, the very dubious state of [the climber's] Tarbuck knot!" At that time, the Tarbuck's unique properties intrigued me, but the fact that it might be insecure under certain circumstances made me apprehensive.

With a bit of experimentation, I devised a variation that seemed a bit more secure, and I have used this variation for more than 30 years to secure Tyrolean traverse and Highlines around trees and structural pillars. The method of tying is depicted in the accompanying illustrations. The modified Tarbuck knot differs from the original version in how the knot is finished off. The closure uses a figure-eight-like structure that secures an extra part of the line.

What is not shown are the requisite

four round turns or wraps around the anchor tree or pillar. (Four wraps are employed on trees - like a tensionless hitch<sup>1</sup> used in rope rescues - to maximise strength and to allow for tree growth and expansion.) Note the figure eight 'keeper knot' depicted in the finished product. Since highlines can be rigged in pairs for redundancy and added strength, the ends of the lines can be tied together with a Flemish or figure eight bend (or any other suitable bend) for added security.

I have used the modified Tarbuck as the main anchoring knot for an aerial course (a.k.a. challenge course or ropes



*Two modified Tarbuck knots securing safety lines, Kilcoo Camp Aerial Course, Minden, Ontario, Canada; Photo: Hai Pham. Note that the two safety lines are seized together to facilitate ease of clipping carabiners.*



*Ladder Bridge, Kilcoo Camp Aerial Course, Minden, Ontario, Canada;  
Photo: Hai Pham*

course) I constructed twenty years ago (and have maintained since then) at Kilcoo Camp for boys near Minden, Ontario, Canada. This course is about one half kilometre in length.

It contains more than twenty elements (obstacles, bridges, ladders, swings, etc.), over six miles of rope and cord, and over 10,000 knots - hundreds of which are modified Tarbuck knots. The course is unique in that it is constructed with nylon rope throughout. Whereas most other courses are constructed with single 3/8" safety cables for each element (which has been deemed inadequate for Horizontal Life Lines (HLL))<sup>2</sup>, the Kilcoo course generally has four 5/8" double-braid nylon safety ropes per element.

In slow-pull tests to failure performed at Cancord Ropes in Hamilton, Ontario, Canada, (and previous tests) the Tarbuck knot tested at one hundred percent efficiency.

<sup>1</sup> The tensionless hitch is simply three of four round turns coupled with a figure eight loop or figure eight on a bight secured to the standing part of the line with a locking carabiner.

<sup>2</sup> With regard to Horizontal Life Lines (HLL), according to *Challenge Course Standards*, Second Edition (January 1998, Association for

Challenge Course Technology, Page 8. B4.1, WIRE ROPE): "Belay cables, Zip Wires, Flying Squirrels, or other lifelines must be made from "flexible" wire rope. The type recommended for use on challenge courses is 3/8 inch diameter, 7 X 19 galvanised aircraft cable (GAC)." But Miura and Sulowski's research states (Miura, N. & A. C. Sulowski. (1991). Chapter 11, "Introduction to Horizontal Life Lines" in, *Fundamentals of Fall Protection*. Sulowski, Andrew C. Ed. International Society for Fall Protection, Toronto, Page 240.): "Generally speaking, the MAL [Maximum Arrest Loads] should be kept less than one-third of the minimum breaking strength of the wire rope. Therefore, in general, 3/8-inch diameter wire rope is not suitable as an HLL [Horizontal Life Line] rope unless an energy absorber is employed in the HLL itself." (Single 3/8" cables without energy absorbers is the norm in all cable courses.) This is one of the reasons why the Kilcoo Camp Aerial Course utilises four 5/8" nylon safety lines per element.

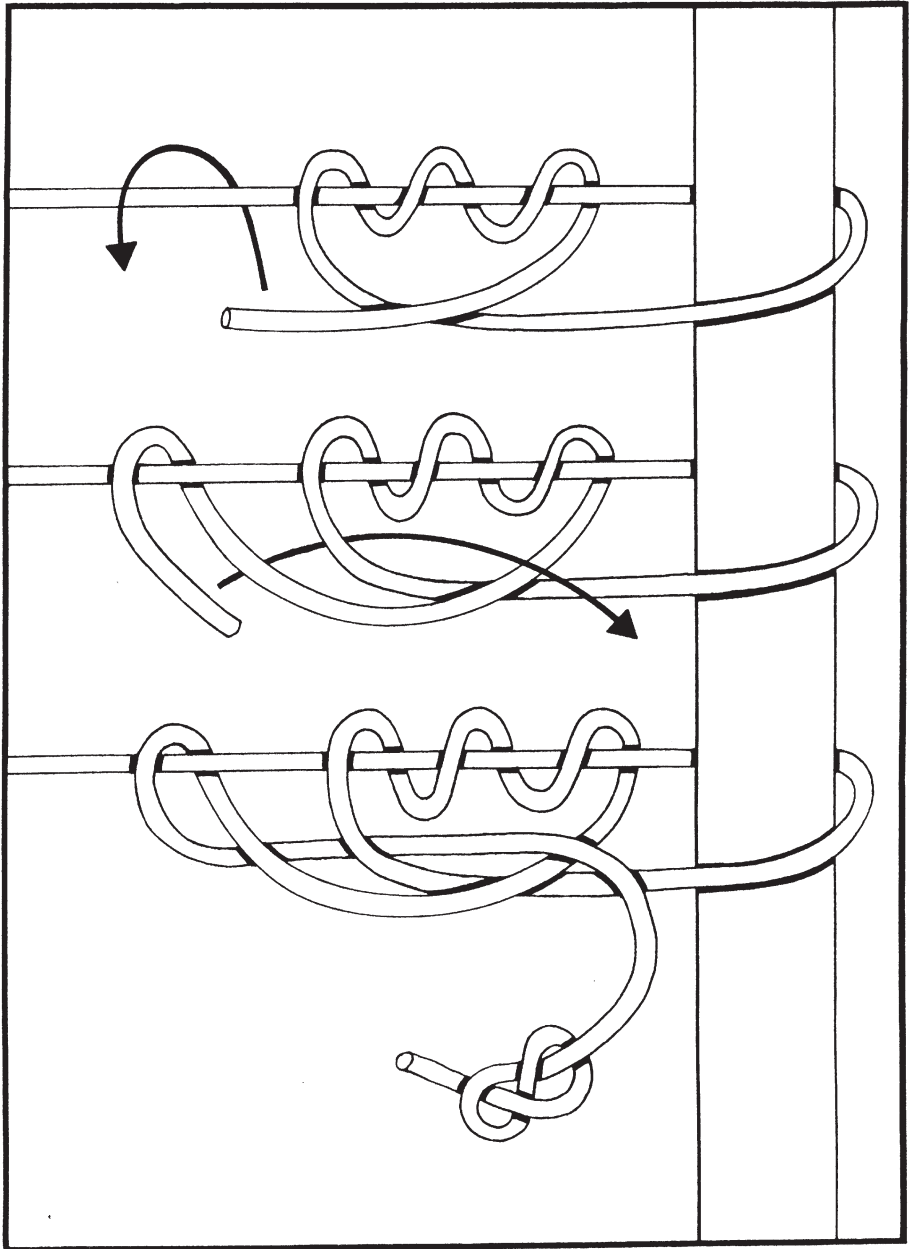

# Bowline Failure

by Heinz Prohaska

In Knotmaster Series No. 22, published in KM84, an anonymous author wrote, "There are scores of fixed loop knots, many of which are alternatives to the common bowline, but they often sacrifice elegance for ugly extra turns and tucks". [1] If knots have extra turns and tucks, it cannot be excluded that a real knotmaster had seen a reason for that. The compromise bowline described in the article may be safe loaded in its main direction (fig. 1), but it can fail loaded perpendicular to this direction (fig. 2). The end can slip out of the knot.

The common bowline suffers from the same problem. The late Ken Tarbuck seems to have been the first author who

mentioned that in a climbing manual after nylon ropes had come into use [2]. How easy this failure could happen in modern climbing ropes - nearly without any force, if the knot is even a little loose - was found by the author in 1967. Warnings in mountaineering magazines were cast to the winds by the clubs for a long time. Finally, accidents showed that the warnings had been justified. If the compromise bowline would come into use in the vertical world, the result one day would be the same.

## References

[1] Anonymous: Knotmaster Series No. 22. *Knotting Matters* No. 84, 9/2004, pp14-15

[2] Tarbuck, Ken: *Nylon Rope and Climbing Safety*. Edinburgh (1954)



Fig. 1  
Compromise  
bowline, loaded in its  
main direction.

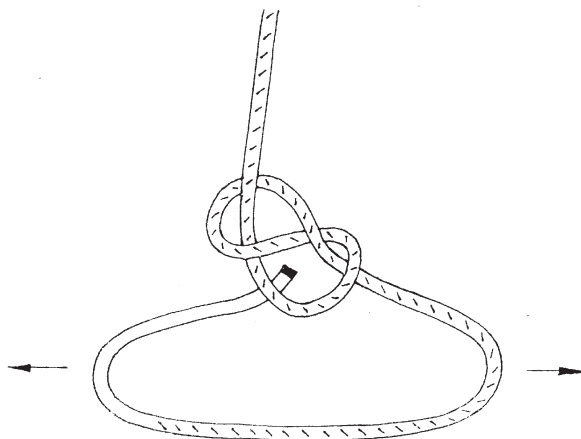

Fig. 2 Failure through ring load.

# Devil's Rope

by 'Hooey'

**B**arbed wire; nasty stuff at best, but for some of us it has been necessary to learn to work with it. Go down any road in ranch country, and you will see fences, mostly of barbed wire and all of it eventually in need of repair. Few like doing these repairs, but I do. In fact, on most ranches I've worked, I'd volunteer for it. The reasons are simple: First it puts me out in the quiet, with my dog for company. Mention that you will be doing fence repair and you'll be fairly certain that no one will interfere with your day. In other words, I like the solitude it has to offer. Second, it invariably involves knots and splices, and that holds my interest. While barbed wire can be difficult to work with, it is just another medium in which I can follow my craft.

Barbed wire fence is built from the top down, usually of five strands [but it can be more or less, depending on requirements], and stretched tight. It doesn't take very long for external forces to wear a fence down. Cattle will 'test' a fence, causing wires to loosen and sag. Corners and braces will lose their integrity, and again the wires will sag. Strands of wire will break for a variety of reasons: staples driven too deeply into a post will crimp a wire, weakening it at that point. Or a lightning strike somewhere along the line will burn off the galvanised coating, leaving the wire to rust and weaken etc. All it takes is a few hand tools, some experience and patience and these problems can be fixed.

After checking to see that the wooden

posts are firm in the ground, corners and braces [H braces] can be tightened by running some wire [smooth or barbed] around two vertical posts of the brace a couple of times X-wise. The wires are prevented from riding up or down on the posts with a nail or staple hammered into the post. A stick is then inserted between the wires of one leg of the X, turned windlass fashion until tight, then prevented from un-turning by resting it against either the wires of the other leg of the X, or against the horizontal member of the H-brace itself. The same tightening is then done to the other leg of the X. The result will be a stout brace, which will support all of the weight of the wires connected to it.

A wire can then be strung to the farthestmost vertical of the corner or brace by taking a few turns around it, then hitching the wire to its own standing part. I go around the standing part at least four times. These are not hitches as we know in rope, but they are hitches just the same. The wire's memory will keep it wrapped tightly.

Should a wire break in a straight run, there are several ways to fix it. The easiest, but not the best, is by forming a loop or eye in one end by the use of the same hitches, running the opposing wire through the loop, applying tension, and forming another loop in the second wire interlocking with the first loop. The tension is then released. Why I don't consider this the best of ways to join the ends of a broken strand of wire is that at that point where the two loops pull against each other a sharp bend occurs



which will weaken the wire somewhat. Still, it's a quick fix, and it does work.

A better fix is the splice. The opposing wires are brought towards each other and the two strands of each side unlayed for about a foot. The two unlayed sections are then "married", leaving a foot of overlap in each direction. This of course is done under tension. Next, one strand of the two strand wire is turned tightly around the standing part of the opposing wire, then its sister strand likewise, just beyond where the first strand ends its turns. The opposite side of the splice is done in similar fashion. Tension is then released, and the wires will lock up against each other much as in a splice or shroud knot.

Barbed wire, like some types of cordage, has a memory. This can be made to work to your benefit. You can see the memory in the wire, and proceed accordingly. But, barbed wire has another trait not common to other cordages that will almost always work against you. It has a mind of its own. Cut some new barbed wire while it is under tension, and you will see what I mean. It can come at you like a rattlesnake.

Work slowly and with patience, and you can minimise the potential for hazard. Show impatience, and you will pay the price.

There are over 2,000 different types/ styles of barbed wire that have been patented since its invention in the mid-nineteenth century. I have worked with only a few, but enough to see that some of the different types require different tools and techniques. And, of course, on every ranch I've worked on there are favoured ways of working with it as well. So the next time you see a piece of barbed wire, rather than reacting to it negatively, consider the possibilities...and of course wear gloves.

*Picture courtesy of Devil's Rope Museum*

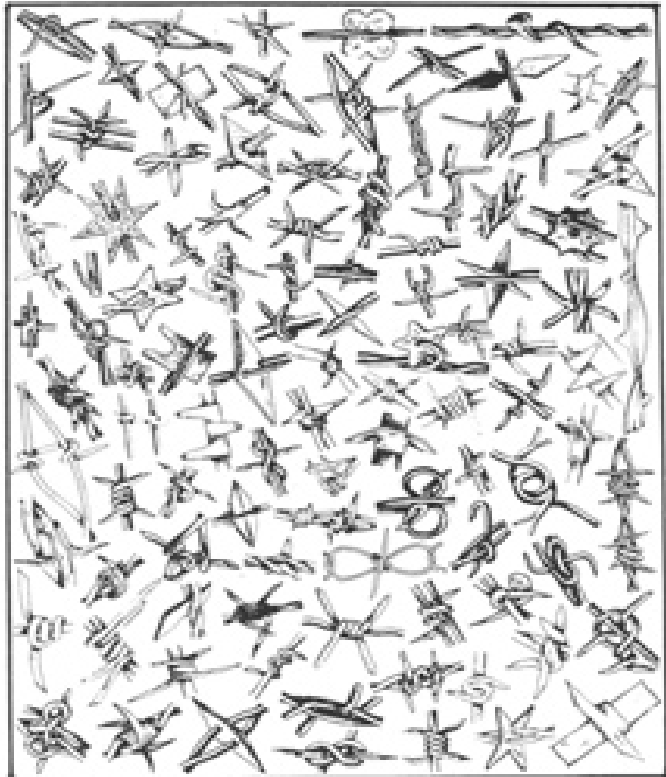



# Knot Gallery



*Above: Spanish Ring necklace made in 1.5mm leather lace and one inch beads -  
Robert Black (America)*

*Facing: Decorated bell from C E 'Bud' Brewer (America)*

*Overleaf: Sailmaker at work -Yngve Edell (Sweden)*







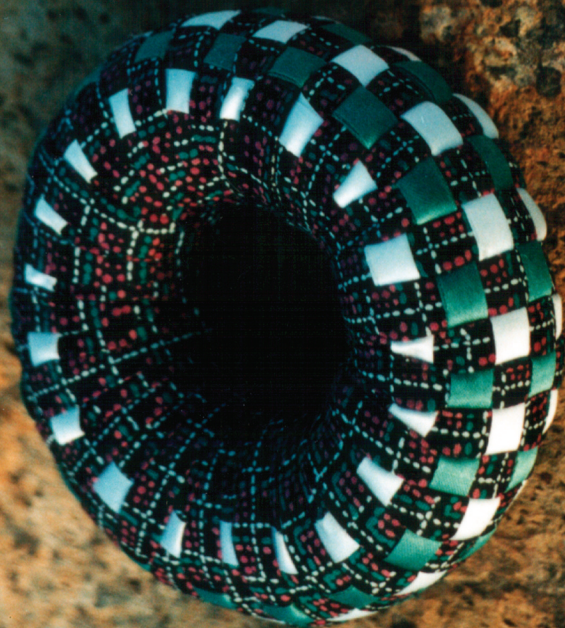
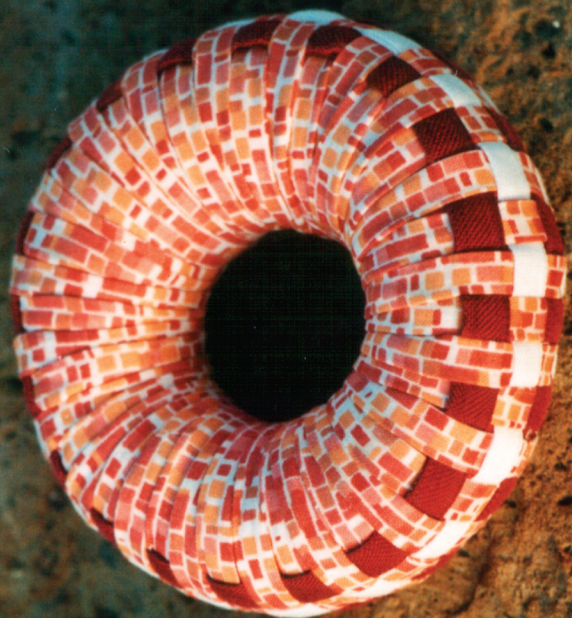

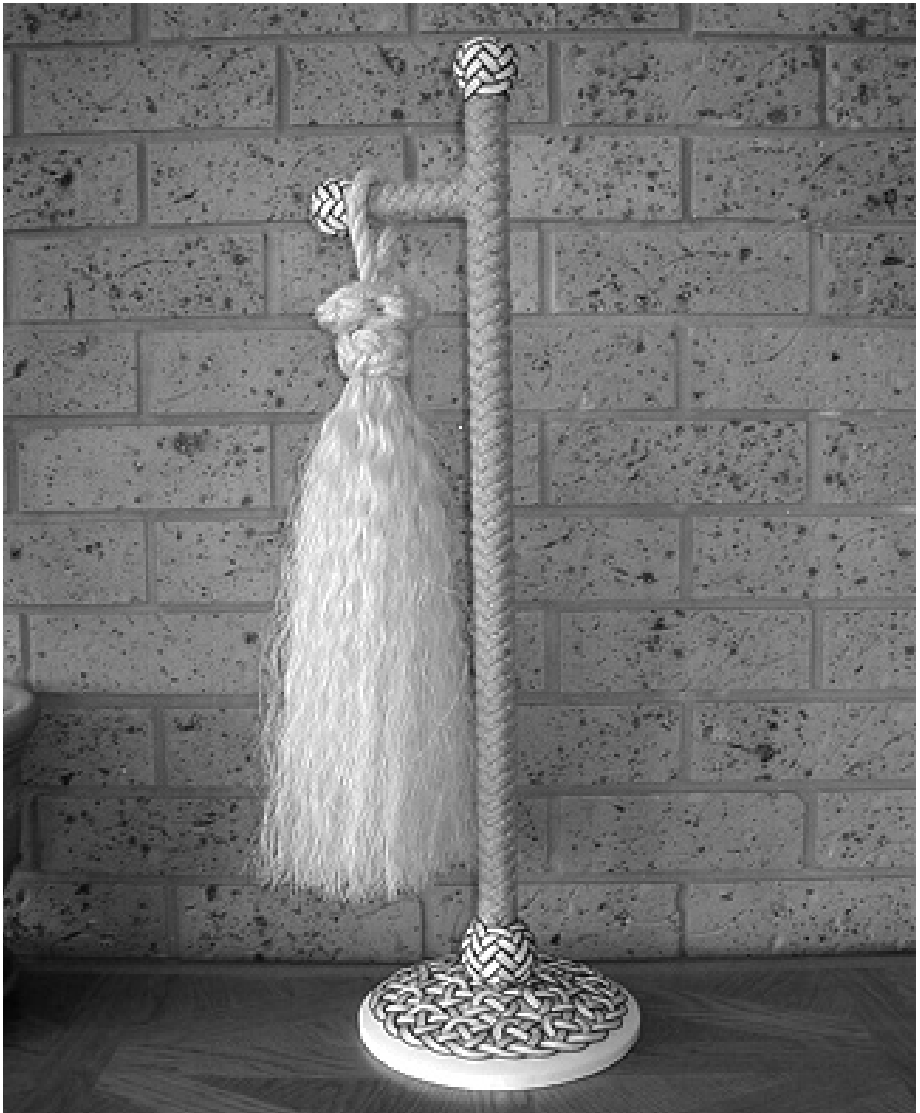

*Above: Comb Hanger by Ron Hodgens (Australia)*

*Facing: Fly tying tools by Jens Gunne Johansen (Norway)*

*Overleaf: Napkin rings from Joaquim Paulo Escudeiro (Portugal)*

*Back Cover: An intrically knotted bag from Satish Patki (India)*





THE FLY DRESSERS' GUILD



# The Rosary Knot

by Geoffrey Budworth

*'...the Greek Orthodox monks of Mount Athos use a rosary of 100 knots divided into equal parts by four large beads.'*

(Cyrus Lawrence Day, *Quipus & Witches' Knots*, 1967)

**M**onks and nuns in the Greek Orthodox Church, as well as priests and lay people, use the knotted rosary with the Jesus prayer - 'Lord Jesus Christ, Son of the Living God, have mercy on me [a sinner]' - which they recite 25 times (once for each knot), followed by the Lord's prayer (when a bead is reached), then repeat the sequence three more times.

The rosary knot is actually a Sailor's Knife Lanyard Knot (A#787), but tied by a bewildering combination of wraps and tucks which the unknown originator, according to legend, was vouchsafed in a vision from God. Indeed, during the hours of a day it takes an individual to tie a complete rosary of 100 knots, using eight and a half arm lengths of black knitting wool (the sort used for socks), he or she is required to repeat the Jesus prayer continuously; and, if a knot goes awry, the cause is deemed to be a lack of due devotion. IGKT knotting workshops are never that rigorous. Guild members ought, I suggest, to learn the rosary knot because it is one of those fabulous beasts summoned up from time to time by outsiders to test us. Fear not. It is easily tamed. Use two different coloured cords, each about 0.75-m [2' 6"] long, and 3-mm diameter [0.3-inch circumference].

Tie the two cords together. This knot will be untied later, when the first rosary knot has been completed.

**Fig. 1** - Place the knot behind the 1st finger of the left hand and take strand A across the palm and between the 3rd and 4th fingers; then pass strand B behind the three fingers and back onto the palm of the hand between the 3rd and 4th fingers. Wrap strand B around the thumb to cross over itself at the centre of the palm.

**Fig. 2a** - Pick up strand A from in front of the 2nd and 3rd fingers, pulling out a bit, and place it over the thumb above the loop of strand B.

**Fig. 2b** - Next remove strand B from the thumb, lifting it over strand A, and relocate it on the 2nd finger.

**Fig. 3** - Take strand A behind the two middle fingers and over strand B - at three places - before threading it under itself. By this process strands A and B create a cross in the centre of the palm.

**Fig. 4** - Pick up the cross and place it over the thumb, leaving the palm empty.

**Fig. 5** - Take strand B behind the two middle fingers and underneath the three strands which extend between the thumb and the 1st and 2nd fingers, then let the end hang down over the palm [fig. 5].

**Fig's 6 & 7** - Pass strand A under strand B, behind the two middle fingers and under the three strands extending from the thumb to the second finger, letting it also fall freely down over the palm.

ROSARY  
KNOT

Fig. 1

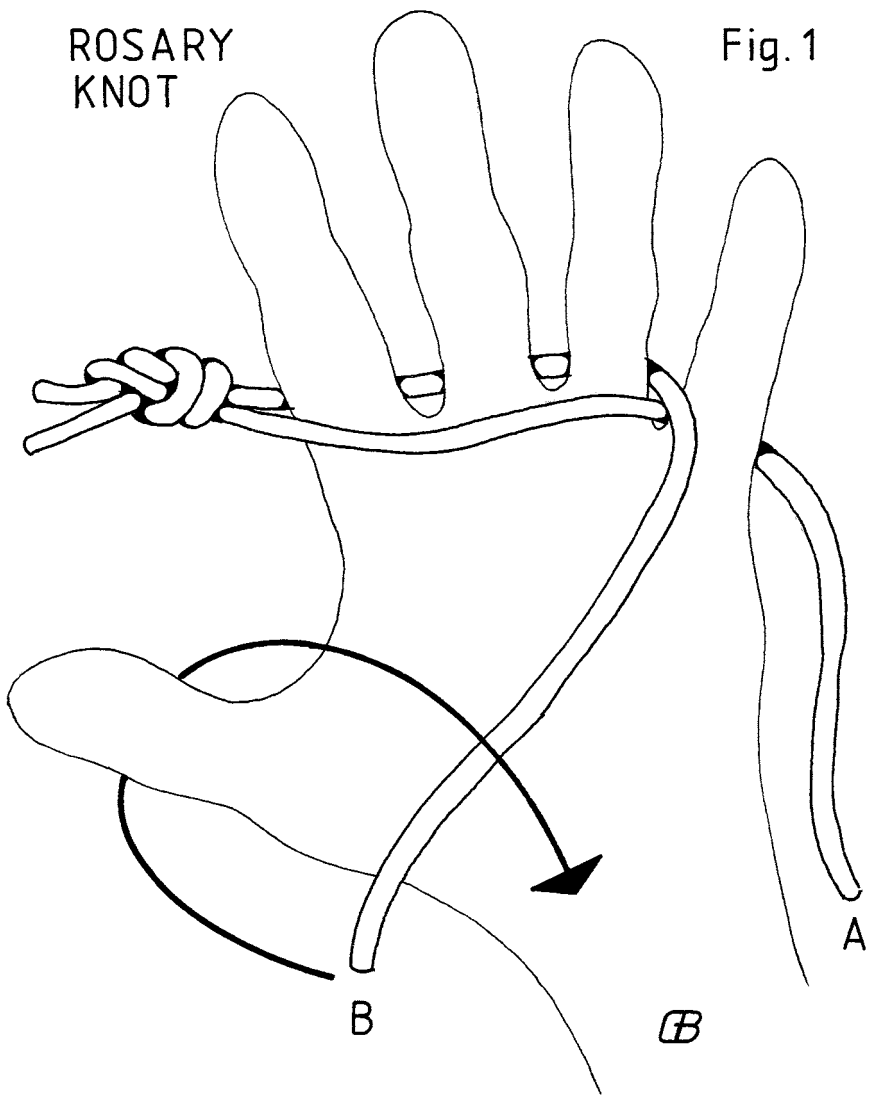

[The foregoing steps remind the faithful of the 7 days of creation in the Book of

Genesis, and the 7 Churches of the Revelations.]

Impatient or curious knot students can bail out at this juncture. The knot is

Fig. 2a

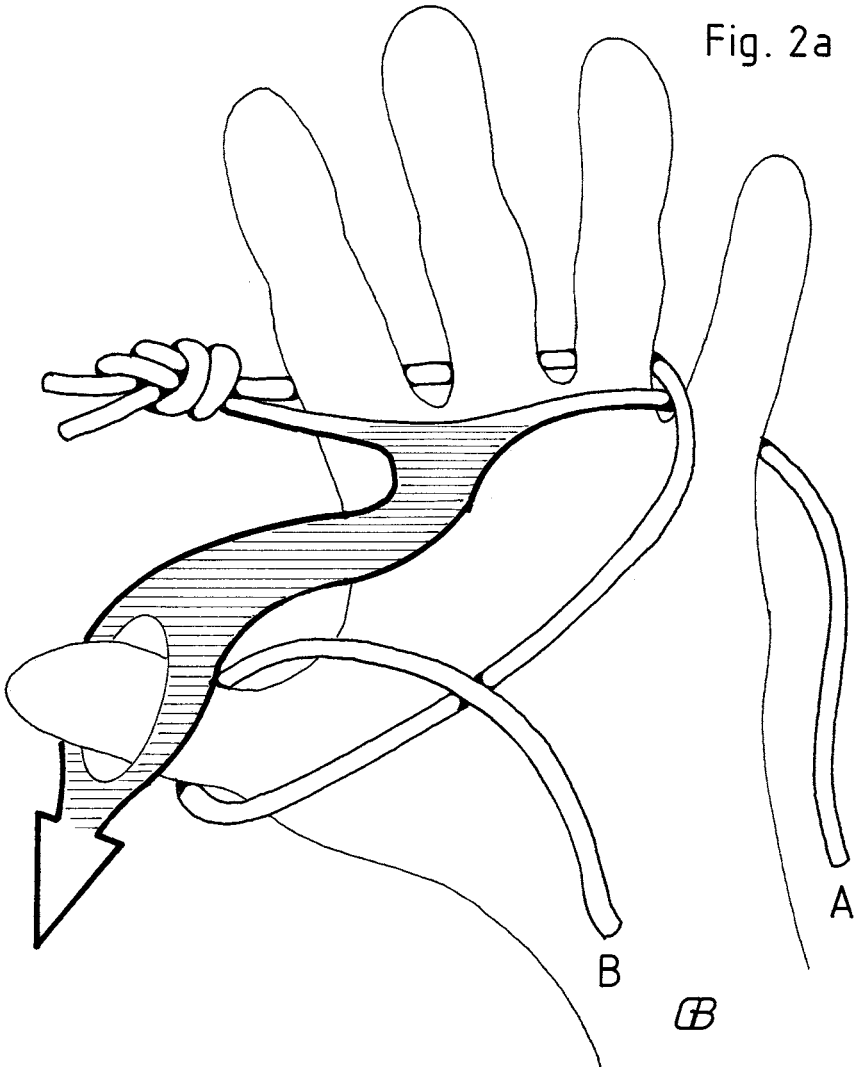

complete. Remove the interwoven cords from the hand, lifting up their knotted ends and letting the two free ends hang down. Mould the nondescript tangle into more of a bird's nest shape, removing

unwanted slack a bit at a time, then tighten the resulting knot.

For those determined to complete the ritual, the final five steps in tying this

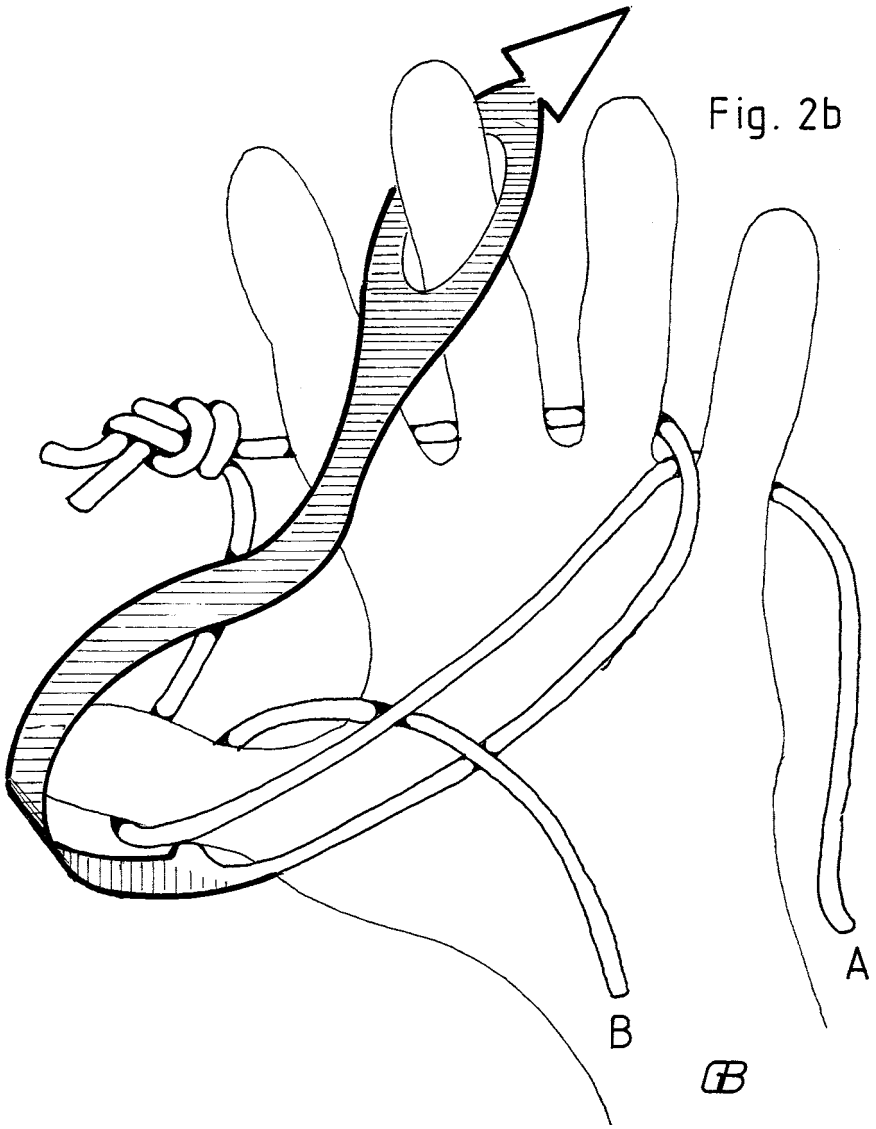

Fig. 2b

sacred knot begin with a cat's-cradle kind of display.

Locate the original strand A behind the thumb as it comes from the first knot but transfer the other two strands from

behind the thumb onto the palm of the hand.

Similarly, transfer all of the cords from the fingers to the palm of the hand, but retain a hold of strand B (the loop

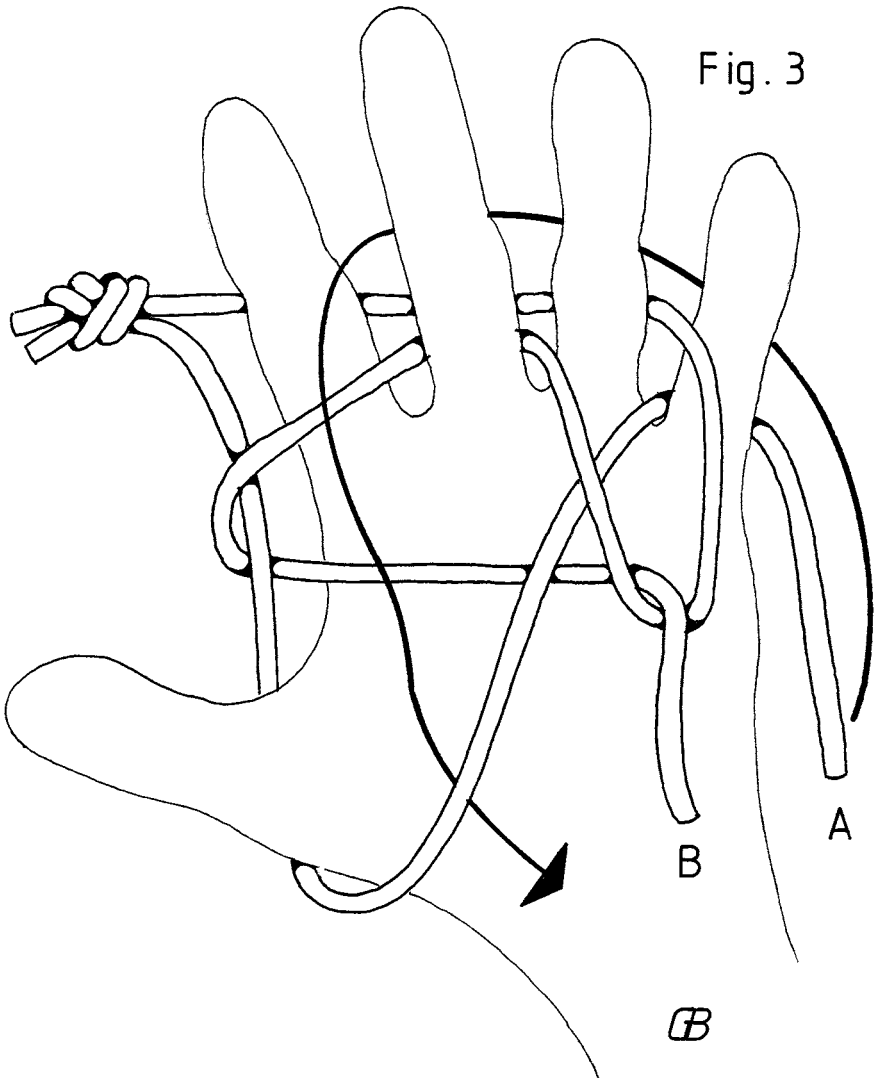

Fig. 3

from around the 3rd finger) and replace it on the 2nd finger.

Spread the three loops into the form of a cross - the original knot uppermost (1st finger), strands A (thumb) and B (2nd

finger) as the horizontal arms - pulling down judiciously upon the two ends with the right hand to partially tighten the knot with an overall even tension [fig. 8].

Fig. 4

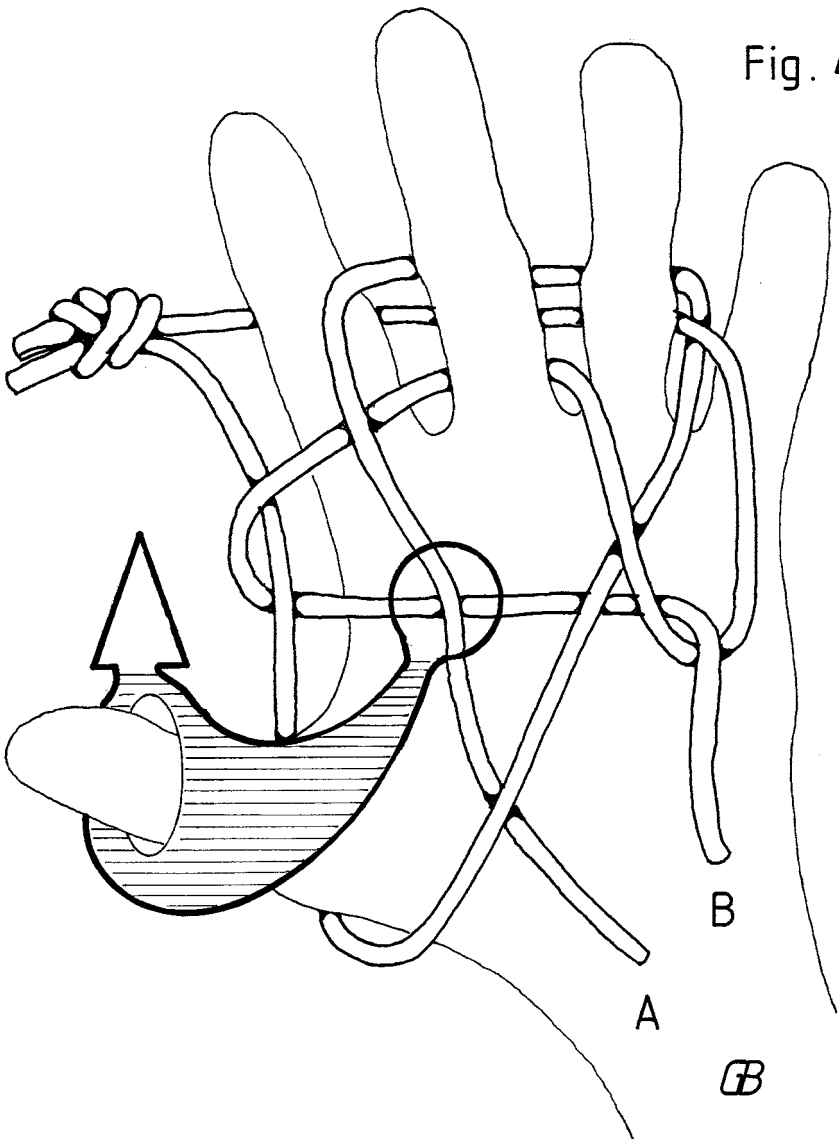

Run the knot up the stem towards its source by pulling a leg of both loops (as shown).

Hold the right loop against the stem and work first with the left loop pulling it three times through the knot. Then hold the left-hand loop against the stem and

Fig. 5

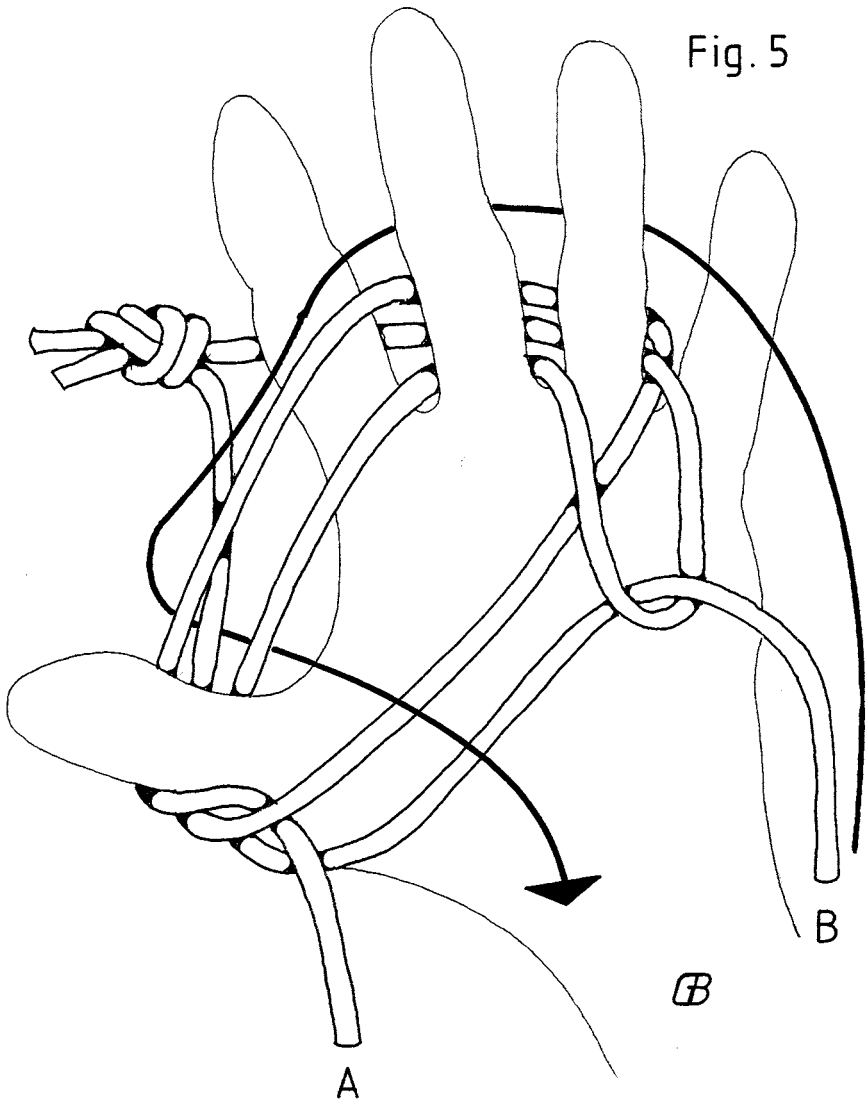

work with the other loop. Finally tighten the knot. The entire process is traditionally done with fingers alone, although one devout Sister admitted to me that she uses a bodkin or other strong

blunt implement to work slack from the top to the bottom of the knot.

[The 12 stages in tying this knot represent the 12 tribes of Israel, the 12 apostles and the 12 gates of the heavenly city of New Jerusalem.]

Fig. 6

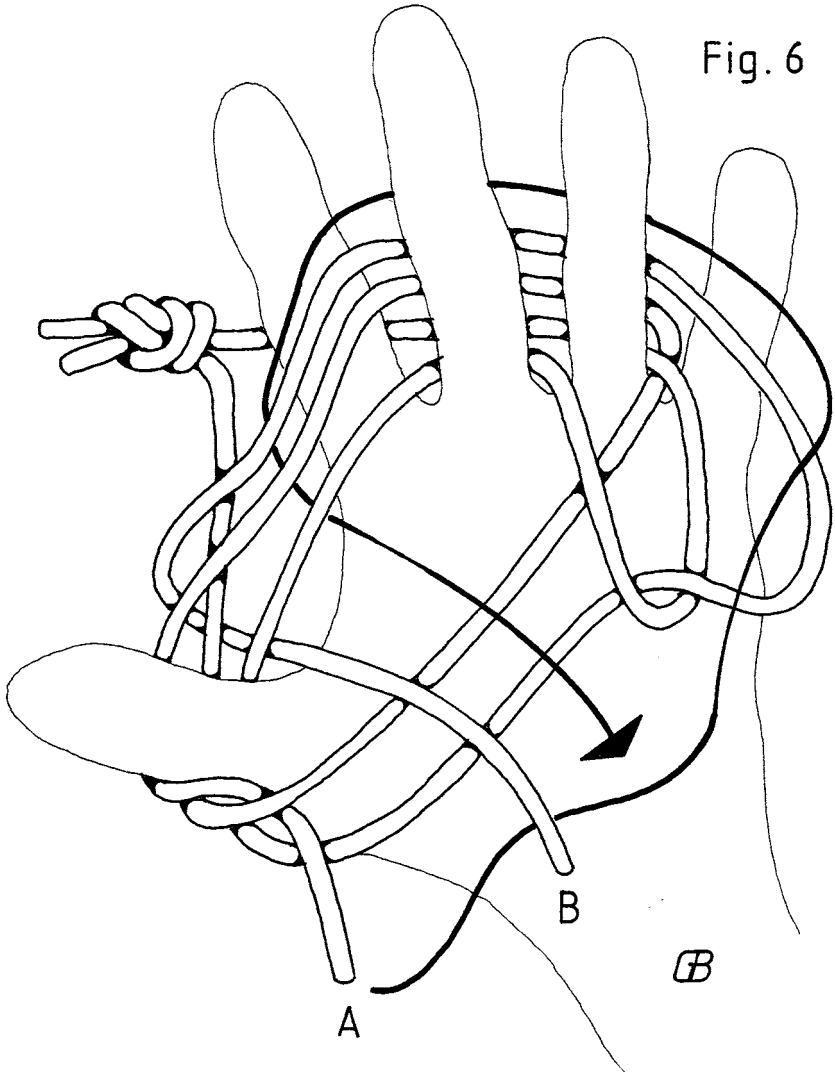



Fig. 7

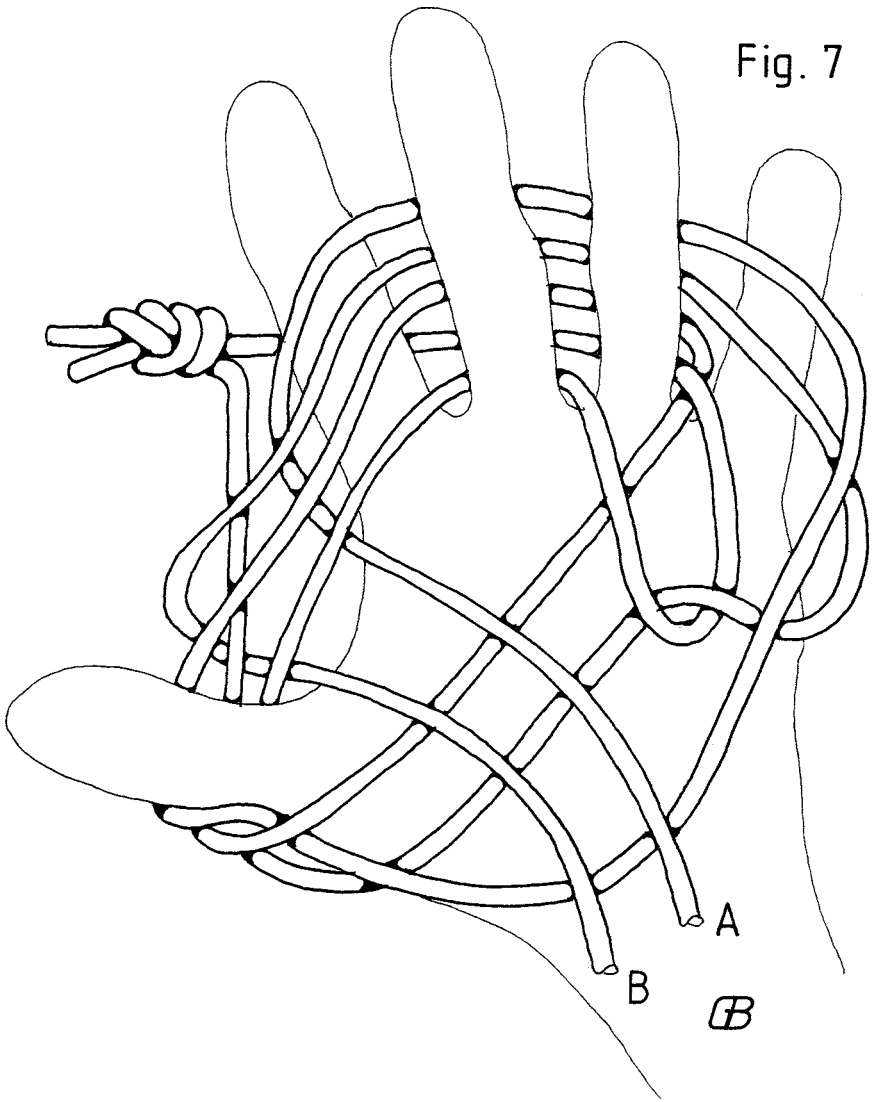
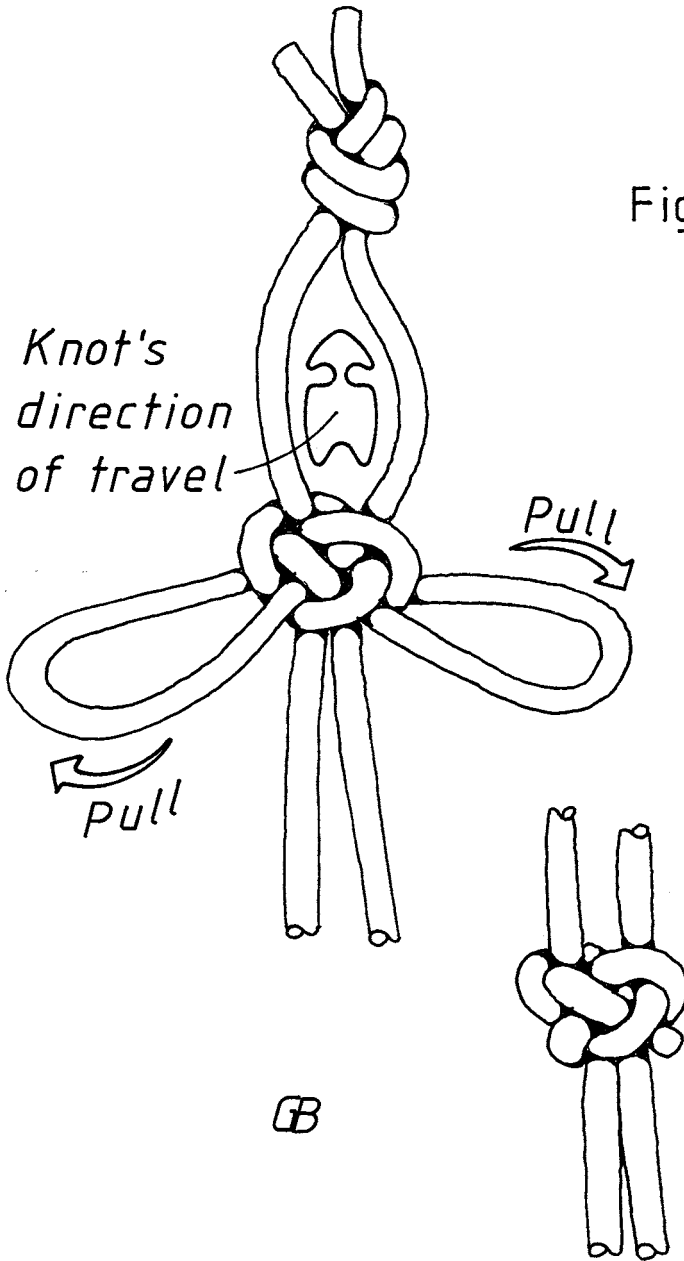

Fig. 8



# Branch Lines

## West Yorkshire Branch

In May it was the fourth time that we have been invited to display at the Skipton Waterways Festival and we always have a lot of interest from the public and particularly from the narrow boat owners. There were eight of us on the stall. We still have difficulties getting a full team of local members, but are lucky in the fact that other members in the Yorkshire and Lancashire area are prepared to travel a long way to be with us. Despite a spectacular storm and cloudburst, which demolished the stand next to ours and effectively finished the festival an hour early, we all had a good day.

In June six of us attended the Stainforth Canal Festival near Doncaster. This is a relatively new event and our first visit. It was refreshing to go to an event where we didn't have the bureaucracy and form filling that seems to go with the more polished events. We took some Scoubie strings with us as the "craze" seems to have a real hold at the moment, and we certainly had a lot of interest from younger people. It was rewarding to have quite small children explain their techniques to us and for us to learn a different aspect of knotting. It

was an enjoyable and constructive day and we are pleased to have been invited back next year.

*David Pearson*

## Solent Branch

A very busy summer so far and it all started with Gordon giving a talk on Ropes and Lines, Knots and Binds at his Flying Club. Question from the audience - can you make us a rope ladder for a Flower Festival? That rope ladder turned out to be a full set of shrouds! Plus an anchor on a cheesed rope and ten pew end lamp brackets decorated with rope spirals and Turk's heads. All in support of the Portchester Flower Festival in St Mary's church in the old Roman Castle at Portchester, which happened to coincide with the Southampton Kite Festival.

The shrouds live on and after testing at the Burgess Hill Carnival they were on display at the International Festival of the Sea where members from the Solent



and Sussex Branches put on a display on behalf of the Guild. The following weekend was the Solent annual pilgrimage to the Queen Elizabeth Country Park Show. At the end of July is the Farnham Model Engineers Show, which you may think is not really 'knotty' - but it is surprising how much interest (and free coffee) we get. Just one event booked for August - "Beside the Sea" at Manor Park Farm Botley; another seemingly contradiction but the Hamble river is in the grounds and was used extensively by landing craft during WWII.

Shroud bookings are also in hand for Durley Church Flower Show and a couple of Trafalgar events in October. The lesson here is - give a talk to any organisation, club, group or even individuals, you never know what seeds it may sow.

Solent Branch meetings continue every other month. Visit the IGKT web site or use the link to the Solent Branch web site for details, because anyone is most welcome

### **G.J.P.**

Our latest meeting was held on Tuesday, 9th August 2005, at 7.30 pm, in the café at the Gosport Marina, across the harbour from Portsmouth, on the English south coast. As it was still remarkably hot and sunny, we foregathered at tables and chairs under cover on the veranda, with impressive views of moored naval vessels as well as the coming and going of ferry ships. Tools, knotted items and cordage were produced and displayed. This was an untried venue, made available by new member Steve Wilkes and Lisa, which proved to be so suitable that it will be

good if we can adopt it as our regular haunt.

Many branches - it seems to me - have a discernible ethos (because members share a common background such as Scouting or boating) and that of the Solent branch is noticeably naval, with such stalwarts as Ken Yalden, Gordon Perry and Bob Pearce arranging and quietly overseeing our activities. The individual entry fee has for some time been a mere 50p, augmented by cash raised from a regular raffle of donated prizes which this time included a fid, a pair of pliers, two knot books, a bottle of wine (bearing the exclusive label of the 1860 warship *HMS Warrior*) and a ball of tarred spunyarn.

The main theme was a workshop by IGKT member Steve Judkins, tanned from a week afloat at the Cowes regatta, who teaches sailing with the Joint Services Adventurous Sail Training Centre and is also author of that handy little Fernhurst Books manual *Knot Know-How* published in 2003. Steve demystified the process of tying those so-called Pineapple knots in which one Turk's head is housed inside another, with a well-prepared and expertly presented demonstration, following which all hands had a go at tying one of these remarkable knots themselves. After an hour or two of finger-fiddling effort, I heard some satisfied murmurs of, 'Yeah! Gotcher!' interspersed with other pleas of, 'Can you show me where I've gone wrong?' And, patiently, Steve did.

At 10pm, as I left to have my parking ticket electronically swiped free of charge by the security staff at the gate (courtesy of our marina hosts) I left

astern a hardcore cadre still talking and tying knots.

### *KM's South Coast Stringer*

## **West Country Knotters**

We start with the sad news that our Honorary Branch Member, Denis (Spud) Murphy died in his sleep during the night of 27/28 June after a short illness. Spud, as we all knew him had a great store of knotting knowledge, which he gave freely to all of us. He will be missed by all who knew him. We send our condolences to his family.

The last six mouths from our AGM in April have seen the West Country Knotters in action on numerous occasions. Firstly there was the AGM, which had been postponed for a week to allow some members to travel to the French AGM. At our AGM the old team was re-elected to office. They are, Chair - Vernon Hughes, Secretary - Tug Shipp, Treasurer, - Richard Hopkins, Committee Member - Clive Sandrey. It was also decided to start the branch meetings at 13:00hrs to give us an extra hour of fun time. On average 15 members attend each meeting. That is about 75% of our membership. Visitors are of course always welcome so if you are in our vicinity on the last Saturday in January, March, May, July, September and November come and join us.

Eight of our members (some with partners) attended the Guild AGM at Beale Park. The venue was an interesting choice and we all had a most enjoyable time.

Richard Hopkins reported back that the AGM of our French branch was well worth the visit with excellent food and

company. There was some lovely work on display particularly ball coverings. The publicity for the event was very good with the papers and TV covering it. Members had a most pleasant weekend.

A SeaBritain 2005 event to mark the 200th anniversary of the battle of Trafalgar in which the branch had planned to participate was cancelled but the preparation was not wasted. Our Chairman's village was holding an event so the WCK road show went to Yatton Keynell in Wiltshire. It was a glorious afternoon with the temperature in the high twenties centigrade. Members had a busy time answering queries and demonstrating to an interested audience. Throughout the afternoon children and some parents were heard to say when pointing at some key fobs "I know that one, it's a Skoobie. How do you make that fancy end"? ('Skoobies' are the current craze in the school-yard). The six-knot challenge was also attempted with one lad coming back time and time again to have another try. He won the prize for the fastest time.

We have had a number of speakers at our meetings. One of these was Europa Dawson who showed us how to tie extended crown knotting. She was surrounded all afternoon by members eager to learn this technique. On another occasion Dan Hillman demonstrated how to rig a shear leg. With some excellent equipment he explained the various knots and lashings as he tied them. Dan, an ex navy man who also talks to Sea Cadets, had some interesting stories to tell. Members also demonstrated their skills and we all have learnt something new from each other.

Our next two meetings will be held at Almondsbury Scout HQ on Saturday

24th September 2005 and Saturday 26th November 2005 at 13:00hrs.

### *'Tug' Shipp*

## **East Anglian Branch**

"A jolly good time was had by all" would be a good summary of the day when Knot Tyers and their partners meet for the 3rd "gathering" at the home of Duncan Bolt in Thornham, North Norfolk.

There was plenty of time for chatting, exchange of ideas and techniques and just getting to know one another. There was a fine lunch provided by Duncan's friends Cyril and Ruth Southerland and their family.

The theme for the meeting "Something Old - Something New" brought discussion on fenders old and new from Des Pawson; old books and knots by Terry Barns and Tony Lee. A full explanation and demonstration of the making cockle gathering nets as used at Brancaster Staithe, D shaped rather than the round style preferred by the Kings Lynn men: by Cyril Southerland. Brian Lemon had information on the late 1950s fishing methods. Liz Pawson had a new knotted picture frame to contrast with photos of examples from the early 20th century. Wendy Smith bought exquisite macramé jewellery. Jean Fair a relative new comer to knot tying displayed a wonderful pedestal grafted over and set off with Turk's heads. Brian Ladds showed good examples of work base on Skip Pennock's book.

Local member Tim Siddle, bought a knot board complete with the Thornham village sign as well as a knot in a bottle; whilst from Wells next the Sea just up

the coast Geoff Youngman and Bob Huntington had fenders, Terry Watson showed his well made knot boards and other ropework including appropriately a covered handle to a camera stand. Sadly arthritis kept 'Tuffy' Turner at home.

A day of sunshine, with the occasional shower not spoiling the gathering in Duncan's house, barn, bakehouse and garden. We were sorry that you all could not have made it. Duncan says, God willing, He would like to have a 4th gathering next summer, we all hope to see you there.

*Des Pawson*

## **Pacific Americas Branch**

This year the IGKT-PAB AGM was held over the July 4th weekend, to correspond with the Festival at the Center For Wooden Boats in Seattle. This is a wonderful venue, on the water at Lake Union, within sight of the Space Needle. Our AGM chairperson, Dennis Armstrong, did a great job getting us a prime indoor location, plenty of stage time and secure storage at night. He also got a good location for our meeting and dinner, within walking distance of the show site. The Tall Ships were in Tacoma so the CWB did not have the anticipated crowd, I have been told over 10,000 visitors. Patrick Ducey kicked off the weekend with a tour of one of the mega-yacht factories. After that we all met at CWB and set up our eight tables.

Patrick set out his wonderful display of complex Turk's head knots; cruciform, chalice, goblet and a chess set, as well as the tools and templates that he has developed. Dennis brought the products of "The Knotted Line", fenders, mats, bell ropes, beackets and other



masterful work. Carol Wang set up her working display of Chinese knotting. Lindsey and Kim Philpott brought the display items from the California collection (well as much as the airline would permit).

Bob and Sue Bosch donated hundreds of gallons of bottled water pre-packaged in IGKT-PAB logo labeled 20oz bottles. They (and Karin Bosch) attended our “on stage displays” and did some touring of the Puget Sound area. New member, Brian Broadmoor spent a day with us working on the mathematical implications of spherical knots as well as joining us at dinner. Maggie Machado set up her displays of the whole range of split ply braiding, mats, Turk’s heads and her fixed display frames of the wide variety of fancy knot work that is at her command. She was working under “torn timing”, for (as a surprise) her family had taken this opportunity to gather from many places and celebrate Maggie and Doug’s 40th Wedding Anniversary! Now, I ask you... given a family gathering for a “big deal” in your life or spending time with knotters... Well our Maggie, once again threaded the needle. Your President dragged a few hundred pounds of display knots and teaching aids and piled them in his usual disarray on two tables. Although the CWB prepared a printed schedule the visitors seemed to shun all of the demonstrations. Not only were our presentations almost unattended but the presentations by sailmakers, bronze founders, net makers, varnishing and woodcarvers were often presented to an audience of one (or worse). The total opposite was true at our tables. This where we could catch them one by one: “What knots do you tie?” “So, like, what, like your shoes fall off?” (or, bless me they have velcro.)

“so there are no knots in your world?” Many just want to move on but many will stay to talk about knots. Isn’t that why we do these shows? I never got to see the rest of the show and learned to eat standing up and tie knots one-handed while balancing a plate of food. One bittersweet part of the event was the memorial gift of Clint Funk’s training table by his son Steve. I had a brass plate engraved to affix to the table. With all the bustling about at set up we did not get to pick up the table but when we opened the doors on Saturday AM there was the table, thoughtfully delivered by Steve in the night. The table will get many years of good use and the brass will let people know how it came to be with us.

Patrick put a cap on Sunday evening with an excellent Salmon BBQ at his home with his wife, Kathy, making us all feel like part of an extended family.

Of course Monday was a full day, with Dennis and me holding out until they locked the doors. And fireworks too!

In summary I’ll say that we recruited some new members, taught hundreds of people new skills or refreshed their old ones, handled the AGM business in one hour and thanks to some very generous donations put money in the IGKT-PAB treasury. We will publish the minutes of AGM under a separate heading, suffice to say that we appointed AGM chairpersons to work toward a good event in 2006 and 2007. Both events will be at new locations so the opportunity for other members to attend without extensive travel will be there as well as an excuse to rack up some windshield time or air-miles for the rest of us. Get ready for SF Bay area in ‘06 and perhaps Vancouver BC in ‘07.

*Roy Chapman*

## North West Branch

The North-west branch held their summer meeting during the weekend of 30/31 July, at Quarry Bank Mill, Styal, near Manchester. The management has invited the Guild, to the mill for the previous three years; this venue is proving very well with our members. The mill is owned by the National Trust. Samuel Greg established the mill in 1784 to spin cotton, setting it on the river Bollin where it runs through wooded banks, still rural today, although so close to the centre of Manchester. The mill is still producing spun cotton and we took the opportunity to turn some of this into rope. Along with the mill's rope-making machine the guild members brought along another four machines. Over the two days we succeeded in laying up a large quantity of 12mm cable-laid rope.

This meeting was supported by Allan Spurr, Sue & Roy Morris, Kate Nicholls, Bryan Holmes, Linda & Bruce Turley, Dave Walker, Ken Nelson, Liz & Chris Pinder, Bill Newy, Brian Essex.

The guild have been invited to hold a meeting next year, the dates are to be agreed.

*David Walker*

## German Branch

The fifth meeting to be held in Germany of the International Guild of Knot Tyers took place over the weekend of 20th to 22nd May 2005. We were accommodated on board the four-mast barque *Passat* in Travemuende near Luebeck. Attended by 25 members from five countries and a number of guests, bottle-ship builders and model makers, it was the largest gathering of the Guild to date in Germany.

In addition to the usual exchange of information among insiders, the gathering served to present a working display of our traditional craft to the public. Visitors could not only watch ropes, nets, rope fenders, splices, key tags and the like being made, but they were able to have a go themselves. We also put our wares on show, with the deck of the ship as the perfect backdrop. After some rain on the first day, the weather gradually improved, so much so that we had to seek shelter from the sun.

Many thanks are due to the crew of the ship. With their help, it was another successful meeting. The proposal to meet at Lake Constance next year was met with approval by all, even though it will mean long journey for most. But perhaps the Swiss and Austrian members are then more likely to attend that new venue.

*Peter Willems*



# Postbag

The views expressed in reader's letter do not necessarily reflect those of the Council. The Editor reserves the right to shorten any letter as necessary.

## A Little Gem

The cover of issue 87 of *Knotting Matters* fascinated me because of my special interest in Turk's heads.

The inside page describes it as "\$B x 3L Turk's head in silver." Am I correct in thinking that it is a casting in silver of a Turk's head in plaited cord? One end of the original knot appears to have been pulled through the TH to provide the loop and then trimmed below the knot. The other end is presumably concealed within the knot.

Have any members' experience of making THK's in gold or silver wire?

**John Constable**  
*Pershore, Worcestershire, UK*

*The caption should have read '4B x 3L, but a slip of the editors finger caused a \$ sign to appear instead. Dick Lammes, who made the item wrote, "I made a monkey's fist in full massif silver for my daughters, but my friends where so interested and they "forced" me to make a series of twenty. Now I sell them at the Mediterranean harbours nearby for 40 Euro each.*

*In fact it is a Turk's head like the one in our logo but that doesn't matter.*

*Fundamentals: H approx. 20 mm; diam. appr. 14 mm; weight appr. 13 grams money-silver. There is a smaller version of 6 grams silver as well for 30 Euro."*

## New Bowline?

I write reference the article by Robert Chisnall in KM86. Jolly good and instructive it was too. The thing that puzzles me is, having for the last thirty odd years used the bowline to secure harness, crabs, hooks or any other items to a piece of rope, without any problems. Please do tell me what is the new bowline?

**Casper de Boer**  
*Ipswich, Suffolk, UK*

## Bowline on a Bight

I recently came across an old USN *Training Course for Boatswain's Mate* first issued in '48 and as a third edition in '64. In the section "Marlinespike Seamanship" is a description of a single bowline on a bight that I think is quite an improvement over the type generally shown in most knotting books. It certainly is much easier to tie and elegant in its simplicity.

Further on in the manual, this knot is shown in the application of tightening a lashing and a number of other applications come to mind. I would guess that this knot is described elsewhere and possibly one of the members has seen it before.

**Vic Burt**  
*Essex, Connecticut, USA*

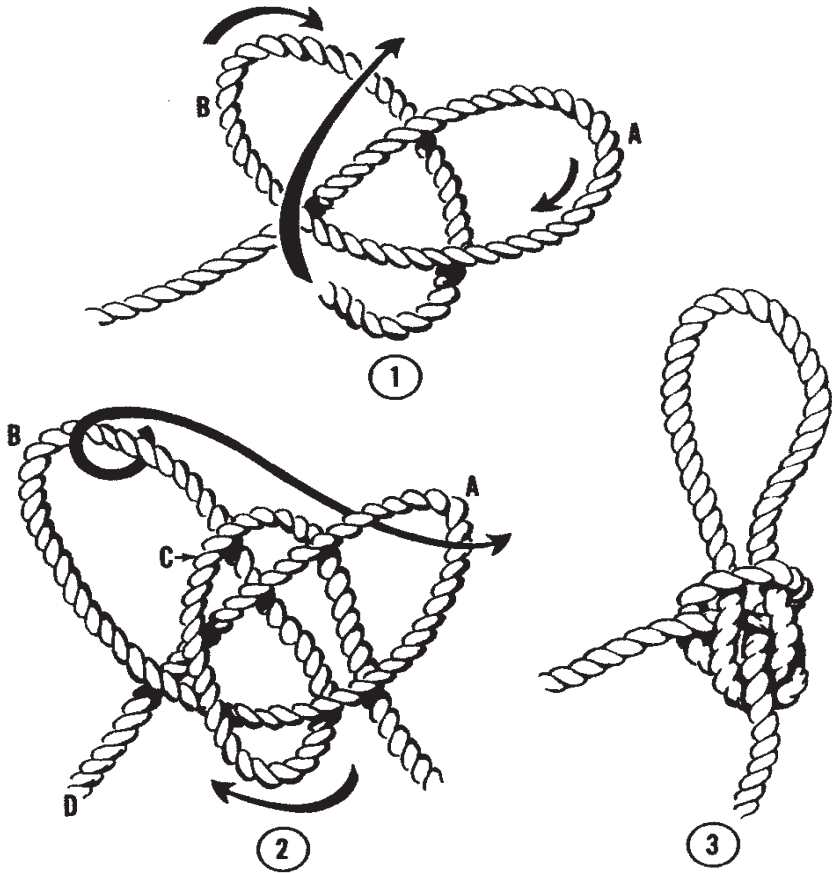

SINGLE BOWLINE ON A BIGHT

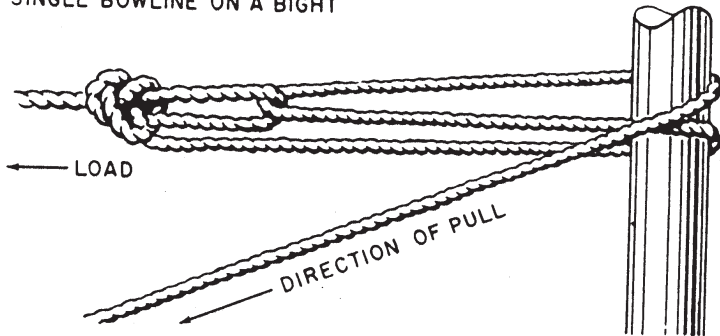

## Repetitive Strain Injury

I enclose a photocopy of my right hand thumb joint which is the result of splicing three-stranded, mainly manila ropes from sizes 1 ¼" (10mm) to 3 ½" (28mm). Larger sizes were done with the help of a fid and heaving mallet. This thumb joint deformity causes no pain and is still able to perform now as well as it did 56 years ago, as I have been employed in the Royal Navy and a Naval Rigging House until retirement from the Simon's Town Dockyard in January 1996.

The three-stranded man-made fibre ropes are just as hard to splice by hand as natural fibre ropes and often require the use of a fid on smaller sizes. So my advice to the younger generation is to avoid the thumb joint disfigurement by making use of the appropriate tools when splicing hawser laid ropes.

*Bill Jones  
Simon's Town, South Africa*

## Knot crib

I have read that in the Castelvecchio Civic Art Museum in Verona (Italy), in the room XVIII there is the painting "Presepio del nodo" (knot Christmas crib) attributed to Liberale da Verona. Can a IGKT member's visiting Verona says what is the knot and who wear it? Thank you.

*Gino Petrollini  
Mentana, Italy*

## RNLI Appeal

I make knotboards of all sorts, and the profit from selling them goes entirely to the Royal National Lifeboat Institution.

Can I appeal for other members to consider doing likewise? They (the RNLI) have to raise every single penny they need in order to save lives at sea.

*Elizabeth McGeorge  
Burntisland, Fife, Scotland*

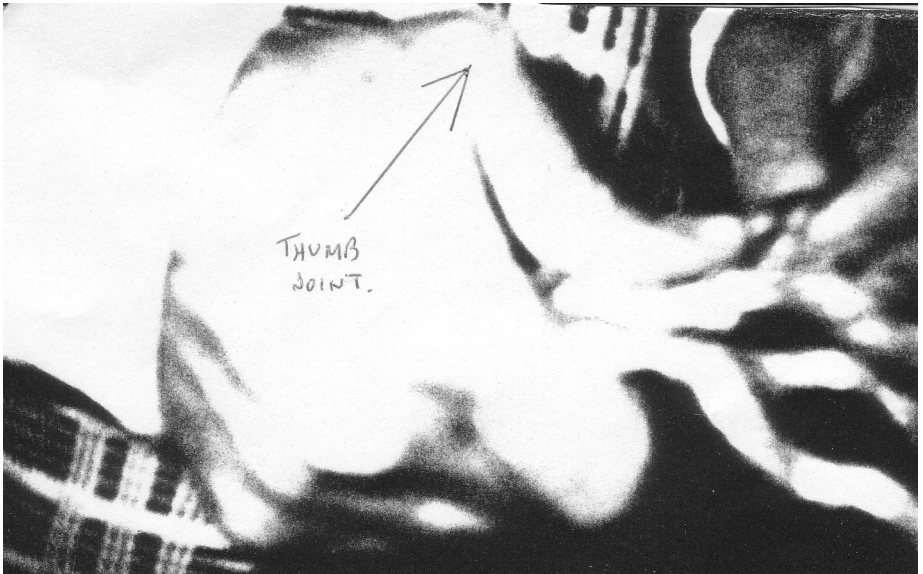

## Double Monkey's Fist

In response to Thomas Simpson's question about a double monkey's fist "Rare Knot or Not" (KM82 p. 33), I think the first part of the answer was given by Ken Yalden. In his article (KM84 p. 46-47) he defined a double monkey's fist as Ashley # 2207, wherein the three circles of a single monkey's fist are doubled to produce 24 facets.

As Tony Doran said (KM85 p46-47), this double monkey's fist with 24 facets doesn't correspond to the knot presented by Thomas Simpson because that would lead to having 16 facets on the hidden side. Tony Doran proposes a 4 bight-3 lead Turk's head, but this version has only 8 facets and none on the back.

As Tony Doran said about Thomas Simpson's knot, "you can see four facets in the middle, but barely four edges on the periphery". According to the laws of symmetry, we can imagine that there are between three and five facets on the other side. As twelve is the only possible number between eleven and thirteen, I think Thomas Simpson's knot comprises

12 facets.

Two solutions: a 3 bight- 5 lead Turk's head or a monkey's fist with four circles (Ashley # 2206).

The 3 bight- 5 lead Turk's head is not a very good spherical knot, so I am sure what we have here is a monkey's fist with 12 facets. It could be called a "double monkey's fist" because it has double the number of facets of a standard monkey's fist.

*Luc Prouveur  
Fécamp, France*

## Bull Ropes

Will the young fellow that corresponded with me last year about bull ropes, please write me again. I need your mailing address.

*Mike Storch  
3890 C.R. 134  
Hesperus, Colorado  
81326 USA*

*Left, a 3 bight 5 lead Turk's head.  
Right, a double monkey's fist (Ashley # 2206).*

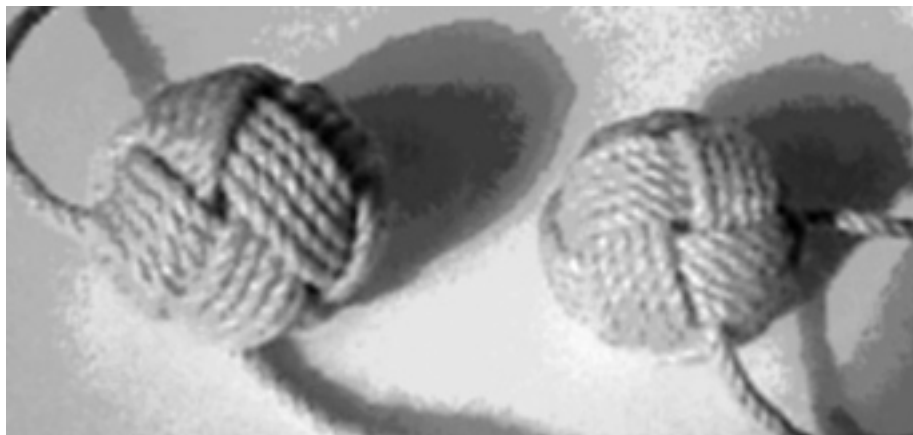

# Knotting Diary

## **AGM & 1/2 YEARLY MEETING**

### **Half-Yearly Meeting**

8th October 2005  
Den Helder, Netherlands  
Contact: Willeke van der Ham  
Tel: 025 121 3285

### **24th AGM**

13th May 2006  
Lord Hill Hotel, Shrewsbury  
Contact: Alex Carson  
Tel: 01743 356466  
Email: geoknot@msn.com

### **IGKT-NAB AGM**

22nd-25th September 2005  
Charleston, South Carolina  
Contact: Steve Coates  
Tel: 603 498 3025  
Email: shcoates54@comcast.net

## **BRANCH MEETINGS**

### **East Anglian Branch**

24th September 2005  
Museum of East Anglian Life  
Stowmarket, Suffolk  
Contact: John Halifax  
Tel: 01502 519123

### **Midlands Branch**

10th October 2005  
The Old Swan (Ma Pardoes), Halesowen  
Road, Halesowen  
Contact Bruce Turley  
Tel: 0121 4534124  
Email: bruce.turley@blueyonder.co.uk

### **West Yorkshire Branch**

13th November 2005  
Armley, Leeds  
Contact: David Pearson  
Tel: 0113 2572689

### **West Country Branch**

26th November 2005  
Almondsbury Scout Hall  
Almondsbury, Nr. Bristol  
Contact: 'Tug' Shipp  
Tel: 01275 847438

### **SECRETARY:**

Nigel Harding  
16 Egles Grove,  
Uckfield,  
Sussex, TN22 2BY  
Tel: 01825 760425  
E-mail: nigel@nigelharding.demon.co.uk

### **Guild Annual Subscription rates:**

Juniors	£5
Seniors	£18
Families	£22

Corporate by arrangement

Payable by cash/cheque Eurocard, Master-card or Visa. Taxpayers in UK - we would prefer a covenanted subscription.

### **EDITOR:**

Colin Grundy  
115 Upper Eastern Green Lane  
Eastern Green,  
Coventry CV5 7DJ  
Tel: 0794 6841157  
E-mail: knotting\_matters@btinternet.com

### **Advertising Rates:**

	Members	Non-members
Full page	£32	£49
Half page	£19	£22
Quarter Page	£10	£15

# Guild Supplies

## Price List 2005

<b>Item</b>	<b>Price</b>
<b>Geoffrey Budworth</b>	
Knotlore - 2 <i>a miscellany of quotes from fact and fiction</i>	£2.50
The Knot Book	£4.99
Plaited Moebius Bands	£2.50*
Knot Rhymes and Reasons	£1.50*
The Knot Scene	£2.00*
<b>Brian Field</b>	
Breastplate Designs	£3.50*
Concerning Crosses	£2.00*
Eric Franklin	
Turksheads the Traditional Way	£1.50 *
Nylon Novelties	£2.00 *
<b>Stuart Grainger</b>	
Knotcraft	£4.00 *
Ropfolk	£1.30 *
Turks Head Alternatives	£2.20 *
Creative Ropecraft (Hardback - 3rd Ed.)	£9.95
Knotted Fabrics Hardback	£9.00
<b>Colin Jones</b>	
The DIY Book of Fenders	£9.95
<b>Harold Scott</b>	
A Guide to the Multi, Single-Strand Cruciform Turk's Head	£4.00*
<b>Skip Pennock</b>	
Decorative Woven Flat Knots	£12.50*
<b>IGKT</b>	
Knotted Matters copies of past editions	£2.50
(Some past editions available - contact the Secretary for details)	
*bulk purchases of these items available at a discount - phone for details	
Cheques payable to IGKT, or simply send your credit card details	
<b>PS</b> Don't forget to allow for Postage	



